

**Product Manual**

**VIKING**

**EN397-3a 1999**

## One partner all over the world

### Häggglunds Drives

is one of the worlds leading manufacturer of heavy duty hydraulic drive systems. If what you need is low speed and high torque, then Häggglunds Drives should be your partner.

If what you need is a durable drive system that will work under the toughest conditions with a minimum of maintenance, then Häggglunds Drives should be your partner. We develop, manufacture & market complete drive-systems and components of the highest quality, based upon our unique radial piston motors. Our industrial and marine customers are to be found all over the world. They know that when they need solutions, support or service, they have in us a partner they can trust. Häggglunds Drives main office and manufacturing plant is situated in Mellansel, Sweden. In Addition Häggglunds Drives is represented in 40 countries worldwide.



***Worldwide distribution and service organization***

**The content in this manual is subject to change without notice or obligation, unless certified referring to a certain purchase order. Information contained herein should be confirmed before placing orders.**

# Features

## High torques

The Viking motor is a high-torque low speed motor, which can be mounted directly on a winch drum or to a shaft without intermediate gears. This presents many practical benefits which appeal to the users of the equipment.

## Variable speed control

The Viking can drive and brake in both directions with variable speed by smoothly controlling the flow of oil in the circuit.

## Severe environments

The Viking motor is designed to be highly resistant to severe working conditions and environments. The Viking has proven itself on board ships, in underwater applications, in explosive and chemically corrosive industrial environments, in extreme heat and freezing cold.

## High efficiency

The mechanical efficiency as well as the starting efficiency is 97%. Because of the extremely low moment of inertia the motor is virtually insensitive to shock loads, and protects the driven equipment. Viking is still the best tension control motor available.

## Low speeds

Smooth, low speed performance from zero to rated speed without the need of reduction gears and no compromise on output torque.

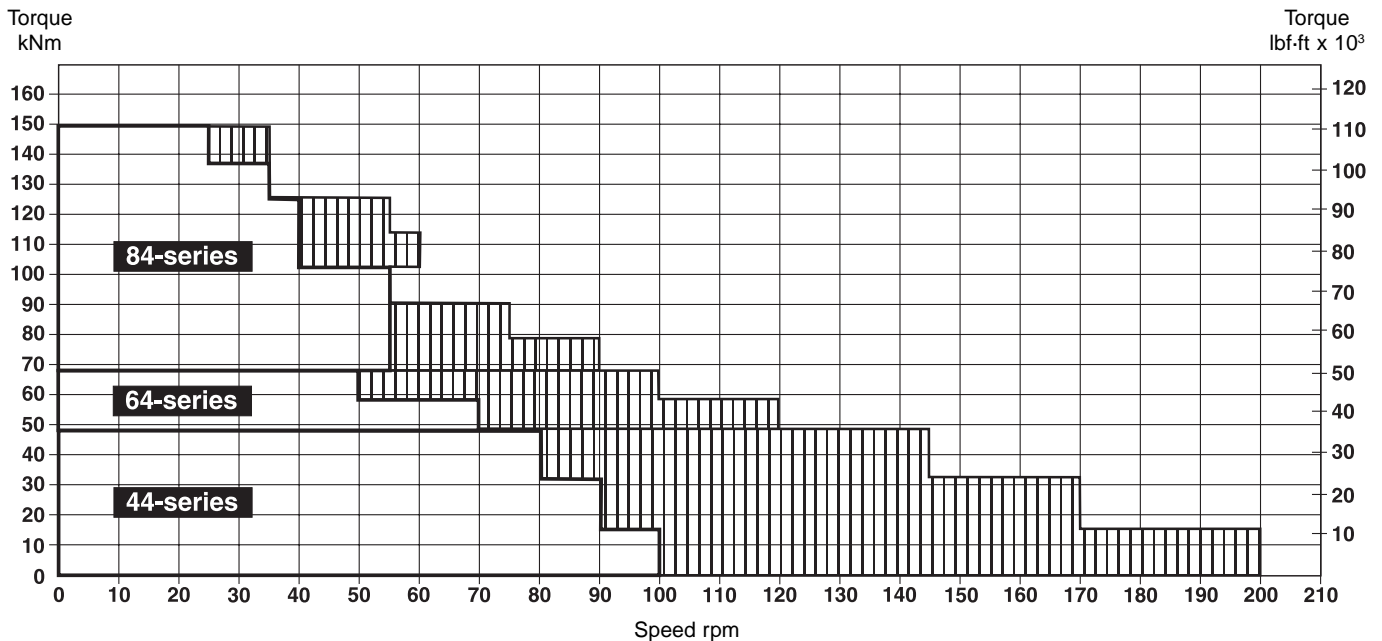
## Safety

For cranes and hoists Viking motors and brake assemblies are DNV approved. You don't need to take risks.



# Quick selection diagram for Viking motors

The diagram below represents the torque and speed, for winch applications. Oil viscosity in the motor case 40 cSt (187 SSU).



For continuous duty and/or operation in line screened area, please contact your Hägglunds Drives representative for final selection.

# Functional description

The Viking motors are radial piston type with rotating case. The case is supported on the stationary cylinder block (5) by two main bearings. An even number of radially positioned pistons (3) work in cylinder bores in the cylinder block, which also houses the inlet and outlet ports (A and C). Each piston is coupled by a piston rod (2) to a cross head pin (6) upon which four cam rollers (7) are mounted. The two inner cam rollers press against the cam ring (8) while the two outer rollers work within their respective guide plates (1). The cam ring is anchored to the rotating case. The distributor (4) directs the input oil to the pistons during their work strokes and returns the exhausted oil back to the tank. The distributor is coupled to the rotating case via a safety coupling (9). The motor can be connected to a driven machine via two mounting surfaces on the rear end of the motor. The symmetrical design of the motor has made it possible to construct it as a 2-speed motor. This means that two different speeds are obtained for a given flow.

The simplest way of performing displacement change over is by connecting a special valve, known as a 2-speed valve, direct to the connecting flange on the cylinder block. The motor is designed so that pressure pulsations in the motor case are avoided. This has the advantage that impurities are not sucked into the case.

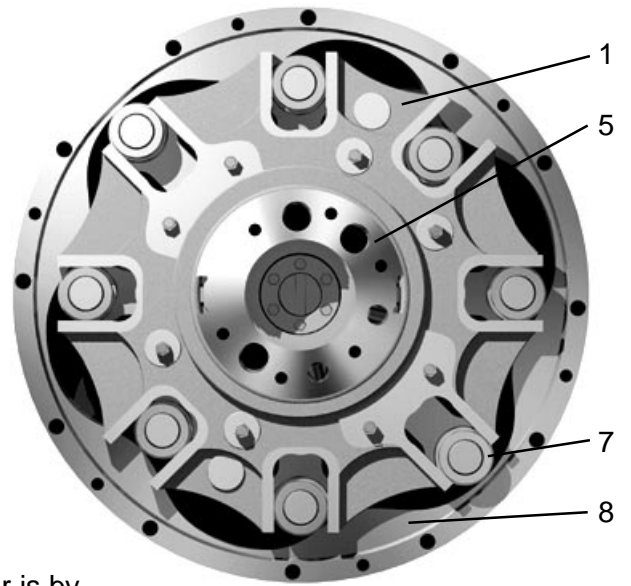
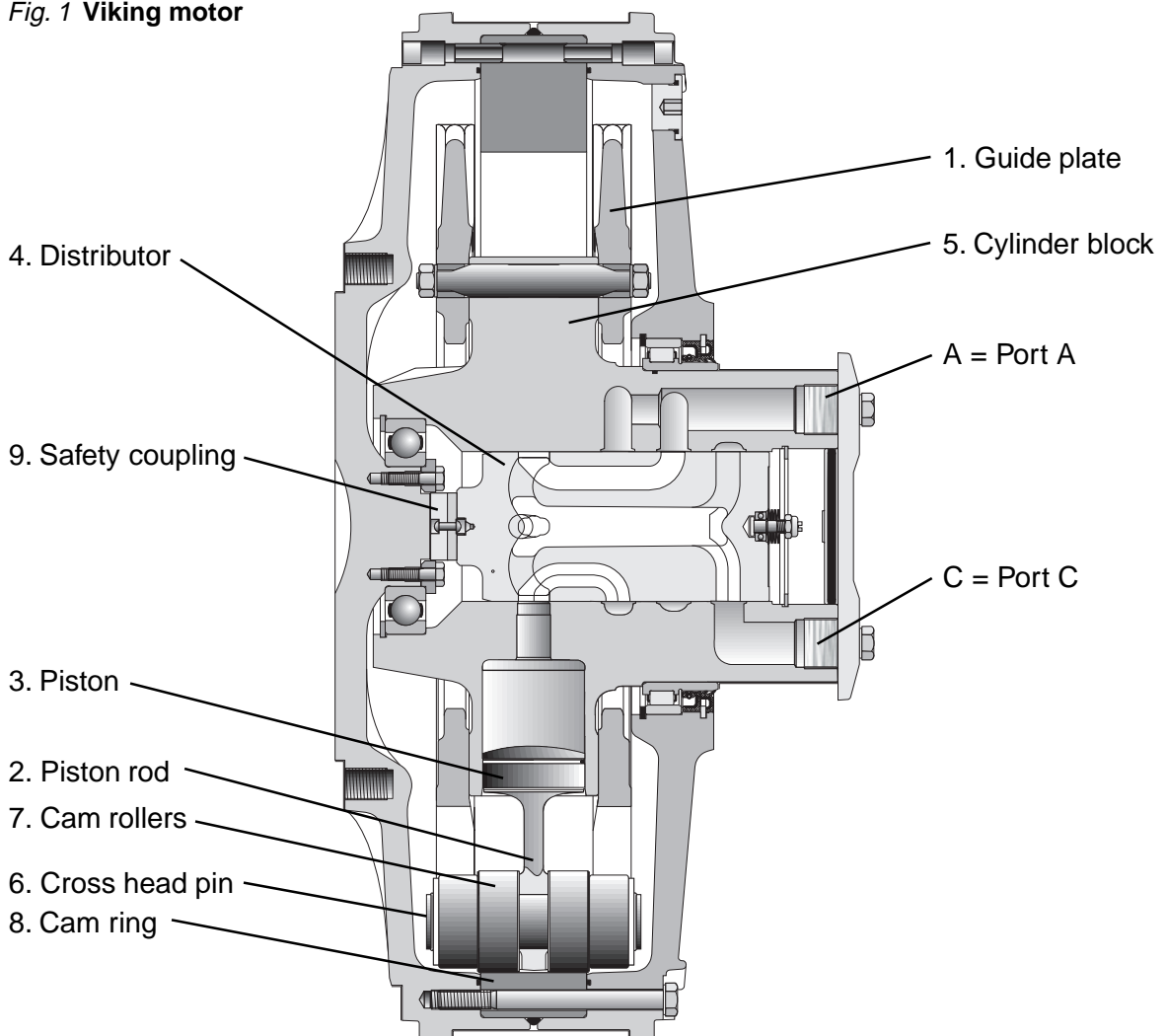


Fig. 1 Viking motor



# Calculation fundamentals

Output power  $P = \frac{T \cdot n}{9549}$  (kW) on driven shaft  $P = \frac{T \cdot n}{5252}$  (hp) on driven shaft

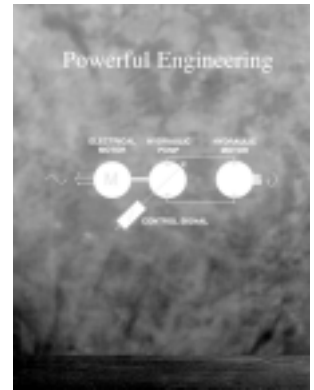
Output torque  $T = T_s \cdot (\rho - \Delta p_l - p_c) \cdot \eta_m$  (Nm)  $T = \frac{T_s \cdot (\rho - \Delta p_l - p_c) \cdot \eta_m}{1000}$  (lbf-ft)

Pressure required  $\rho = \frac{T}{T_s \cdot \eta_m} + \Delta p_l + p_c$  (bar)  $\rho = \frac{T \cdot 1000}{T_s \cdot \eta_m} + \Delta p_l + p_c$  (psi)

Flow rate required  $q = \frac{n \cdot V_i}{1000} + q_l$  (l/min)  $q = \frac{n \cdot V_i}{231} + q_l$  (gpm)

Output speed  $n = \frac{q - q_l}{V_i} \cdot 1000$  (rpm)  $n = \frac{q - q_l}{V_i} \cdot 231$  (rpm)

Inlet power  $P_{in} = \frac{q \cdot (\rho - p_c)}{600}$  (kW)  $P_{in} = \frac{q \cdot (\rho - p_c)}{1714}$  (hp)



For more information  
See Powerful Engineering  
(EN347-4).

Quantity	Symbol	Metric	US	Quantity	Symbol	Metric	US
Power	$P$	= kW	hp	Pressure loss	$\Delta p_l$	= bar	psi
Output torque	$T$	= Nm	lbf-ft	Charge pressure	$p_c$	= bar	psi
Specific torque	$T_s$	= Nm/bar	lbf-ft/1000 psi	Flow rate required	$q$	= l/min	gpm
Rotational speed	$n$	= rpm	rpm	Total volumetric loss	$q_l$	= l/min	gpm
Required pressure	$\rho$	= bar	psi	Displacement	$V_i$	= cm <sup>3</sup> /rev	in <sup>3</sup> /rev
				Mechanical efficiency	$\eta_m$	= 0,97	

## Definitions

### Rated speed<sup>1)</sup>

Rated speed is the highest allowed speed for a charge pressure of 12 bar (175 psi) above case pressure. When a closed loop system is used, a minimum of 15% of oil is to be exchanged in the main loop.

<sup>1)</sup> Operating above rated conditions requires engineering approval.

### Max speed

Maximum speed is the maximum allowed speed. Special considerations are necessary regarding charge pressure, cooling and choice of hydraulic system for speeds rated above.

### Accepted conditions for standard type of motor:

1. Oil viscosity 20 - 40 - 10000 cSt (98 - 187 - 4650 SSU). See page 23.
2. Temperature -35°C to +70°C (-31°F to +158°F).
3. Case pressure 0-3 bar (0-45 psi)  
Pressure peaks and at standstill 8 bar (116 psi)
4. Charge pressure (see diagram).
5. Volumetric losses (see diagram).

\* Related to a required charge pressure of 12 bar (175 psi) for motors in braking mode. Special considerations regarding charge pressure, cooling and choice of hydraulic system for speeds above rated.

\*\* Theoretical value

\*\*\* The motors are designed according to DNV-rules. Test pressure 70 bar/1000 psi. Peak/transient pressure 70 bar/1000 psi maximum, allowed to occur 10000 times.

## Data

Motor type	FULL DISPLACEMENT				Max.*** pressure	DISPLACEMENT SHIFT				Ratio
	Displacement	Specific torque**	Rated speed*	Max. speed		Displacement	Specific torque**	Rated speed*	Max. speed	
	$V_i$	$T_s$	$n$	$n$		$V_i$	$T_s$	$n$	$n$	
44-03300	3325	53	100	200	320	1662	26	100	200	1:2
44-04700	4710	75	100	200	320	2356	37	100	200	1:2
44-06800	6790	108	90	170	320	3393	54	90	170	1:2
44-09200	9240	147	80	145	320	4618	74	80	145	1:2
64-11100	11080	176	70	120	320	5542	88	70	120	1:2
64-13500	13499	215	60	110	250	6750	107	60	110	1:2
64-16300	16340	260	50	100	250	8171	130	50	100	1:2
84-14800	14840	236	55	90	320	-	-	-	-	-
84-17900	17961	286	55	85	320	-	-	-	-	-
84-21300	21375	340	55	80	320	-	-	-	-	-
84-25100	25090	399	55	75	320	-	-	-	-	-
84-38000	38000	605	40	60	250	-	-	-	-	-
84-22300	22300	355	55	55	320	11150	177	60	85	1:2
84-33800	33780	538	35	35	250	16889	269	50	70	1:2
84-25100	25090	399	40	55	250	8362	133	45	75	1:3
84-38000	38000	605	25	35	250	12667	202	35	60	1:3
84-25100	25090	399	40	55	250	16724	266	45	75	2:3
84-38000	38000	605	25	35	250	25334	403	35	60	2:3

Motor type	FULL DISPLACEMENT				Max.*** pressure	DISPLACEMENT SHIFT				Ratio
	Displacement	Specific torque**	Rated speed*	Max. speed		Displacement	Specific torque**	Rated speed*	Max. speed	
	$V_i$	$T_s$	$n$	$n$		$V_i$	$T_s$	$n$	$n$	
44-03300	203	2695	100	200	4650	101	1347	100	200	1:2
44-04700	287	3814	100	200	4650	144	1907	100	200	1:2
44-06800	414	5492	90	170	4650	207	2746	90	170	1:2
44-09200	564	7475	80	145	4650	282	3738	80	145	1:2
64-11100	676	8971	70	120	4650	338	4485	70	120	1:2
64-13500	823	10935	60	110	3600	411	5467	60	110	1:2
64-16300	997	13227	50	100	3600	499	6613	50	100	1:2
84-14800	906	12017	55	90	4650	-	-	-	-	-
84-17900	1096	14546	55	85	4650	-	-	-	-	-
84-21300	1304	17292	55	80	4650	-	-	-	-	-
84-25100	1531	20306	55	75	4650	-	-	-	-	-
84-38000	2320	30756	40	60	3600	-	-	-	-	-
84-22300	1361	18048	55	55	4650	680	9024	60	85	1:2
84-33800	2061	27339	35	35	3600	1031	13669	50	70	1:2
84-25100	1531	20306	40	55	3600	510	6769	45	75	1:3
84-38000	2319	30756	25	35	3600	773	10252	35	60	1:3
84-25100	1531	20306	40	55	3600	1021	13537	45	75	2:3
84-38000	2319	30756	25	35	3600	1546	20504	35	60	2:3

# Ordering codes

In order to identify Hägglunds Drives equipment exactly, the following ordering code is used. These ordering codes should be stated in full in all correspondence e.g. when ordering spare parts.

## Viking motors

**Example:** MK-64-16300-A0-RN-0100

**Mounting alternative** (rotating part)  
Metric  
UNC

**Mounting alternative** (stationary part)  
Key (44/64-series)  
Bolt (84-series)

**Motor**  
44-series  
64-series  
84-series

**Displacement**  
cm<sup>3</sup>

**Distributor**  
Normal  
Severe temp-shocks  
Extremely low speed

**Internal displacement shift valve**  
No valve  
2-position valve  
3-position valve  
2-position valve (ratio 2:3)  
3-position valve (ratio 2:3)

**Direction of rotation** (viewed from oil connection end)  
Clockwise  
Counter-clockwise

**Type of sealing**  
Nitrile  
Viton

Modification  
Standard design  
Special design

Product group  
Class of distributor

Motor 44-series  
Motor 64-series  
Motor 84-series

Individual serial number

611 - - - - -

To be filled in by the manufacturer

## Torque arm

**Example:** TAC-1000-K-0-000

**Torque arm**

**Effective length in mm**  
44/64-series 1000  
84-series 1250

**Mounting alternative**  
Key (44/64-series)  
Bolt (84-series)

**Attachment**  
None  
Stiff  
Pivoted

Modification  
Standard design\*  
Special design

Batch number: .....

\*Bolts and washers are included at delivery

To be filled in by the manufacturer

## Band brake

**Example:** BA-43-S-D-R-000

**Brake assembly**

For motors  
44-series 43  
64-series 63  
84-series 85

Standard  
Marine (eccentric shaft in acidproof steel)

Double brake band

**Braking force direction** (viewed from the brake cylinder side)  
Clockwise  
Counter-clockwise  
Double acting

Modification  
Standard design  
Special design

Week number: .....

To be filled in by manufacturer

## Brake cylinder

**Example:** BCI-M-11-000

**Brake cylinder**

Marine

Low pressure operation  
4-8 bar (58-116 psi)  
High pressure operation  
16-26 bar (232-377 psi)

Without flushing  
With flushing - restrictor Ø 1mm 1  
(low pressure cylinder only)

Modification  
Standard design  
Special design

Product group  
Individual serial number

525 - - - - -

To be filled in by the manufacturer

## Brake bracket

**Example:** BB-46-K-S0-000

**Brake bracket**

For motors  
44/64-series 46  
84-series 85

Key (44/64-series)  
Bolt (84-series)

Single acting, clockwise  
Double acting  
Single & double acting (84-series)

Modification  
Standard design  
Special design

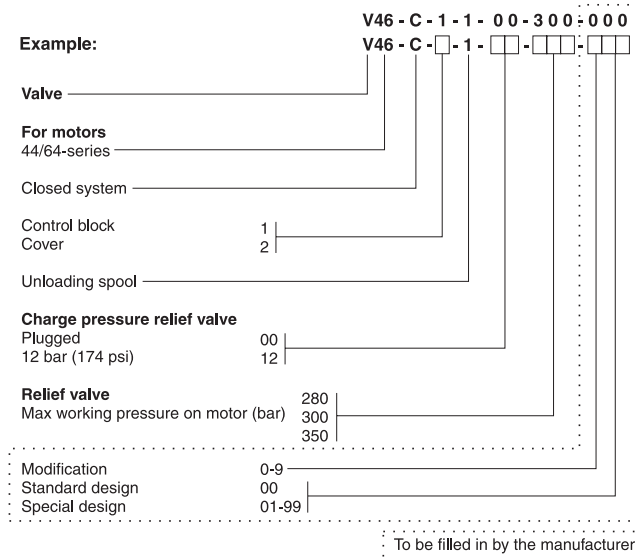
Batch number: .....

To be filled in by the manufacturer

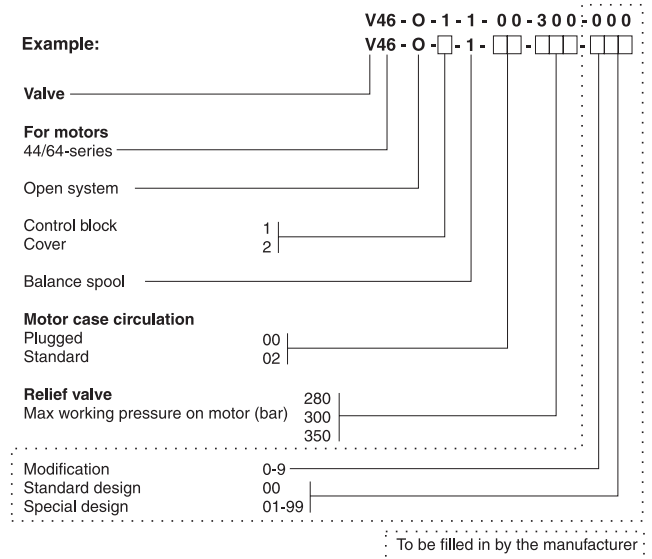
# Ordering codes

In order to identify Hägglunds Drives equipment exactly, the following ordering code is used. These ordering codes should be stated in full in all correspondence e.g. when ordering spare parts.

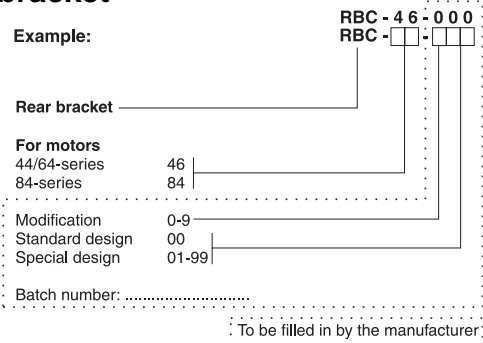
## Valve V46-C



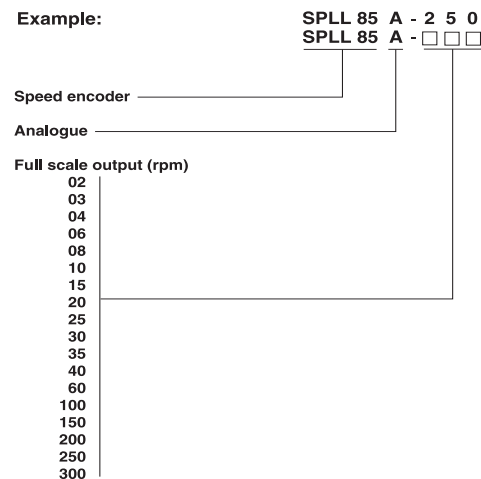
## Valve V46-O



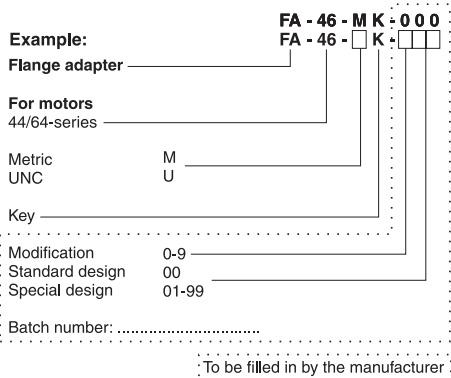
## Rear bracket



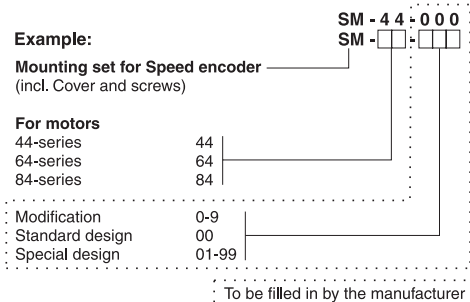
## Speed encoder



## Flange adapter



## Mounting set for Speed encoder



Feature	Advantage	Benefits
Radial piston	Small axial length	Compact - low weight
Multiple stroke design	Large displacement - direct drive Constant displacement High torque/inertia-ratio	Low speed - low noise level Full torque in all positions Quick reversing capacity
Even number of pistons	Main bearings unloaded	High external load capacity
Guide plate design	Transverse piston force avoided High mechanical efficiency	Reduced piston/cylinder wear Full starting torque Superior low speed performance
Cam & guide plate roller bearings	Stick-slip eliminated High mechanical efficiency	Superior low speed performance Full starting torque
Rotating case	Non-rotating pistons Brake surface machined Machined spigots	Free wheeling capability Bandbrake available Direct mounting to winch drum

# Dimensions

## 44/64-series

Fig. 2

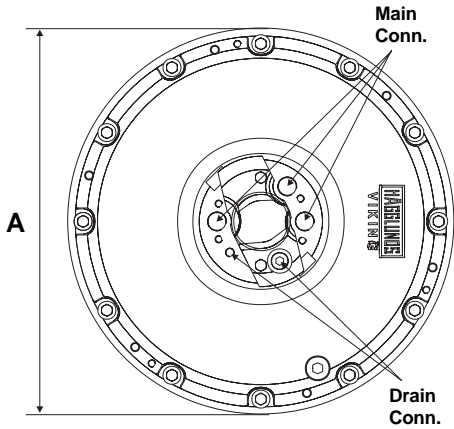


Fig. 3

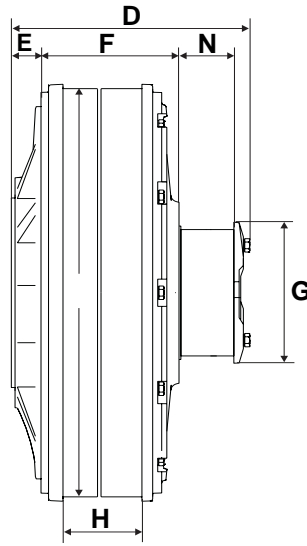
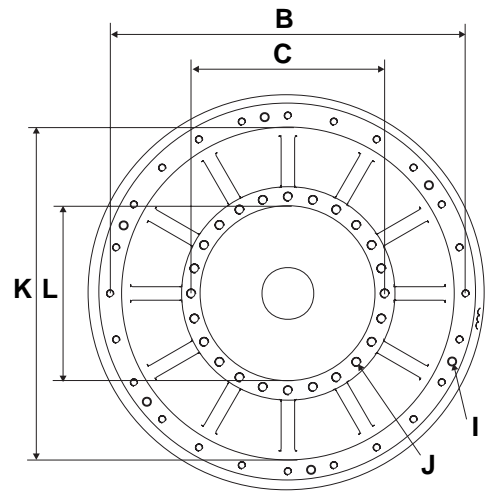


Fig. 4



## 84-series

Fig. 5

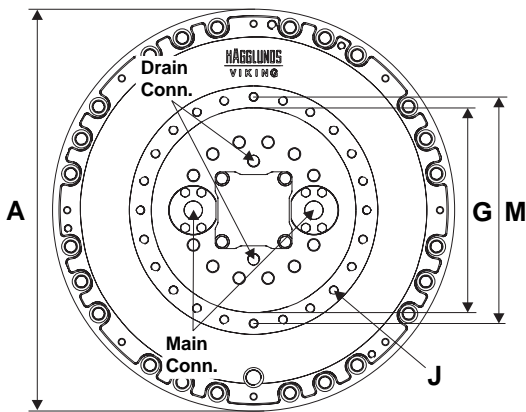


Fig. 6

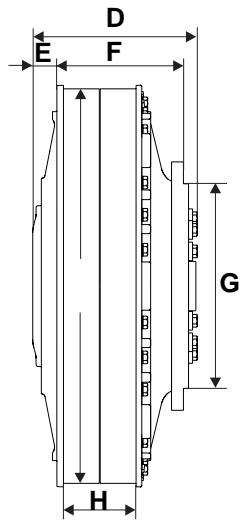


Fig. 7

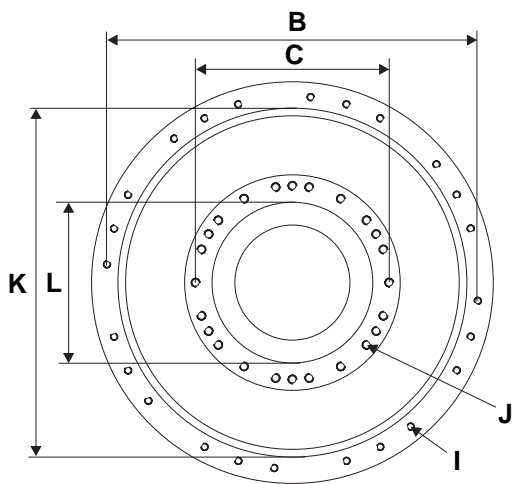


Table 1 Dimensions for the motor

Motor	A mm (in)	B mm (in)	C mm (in)	D mm (in)	E mm (in)	F mm (in)	G mm (in)	H mm (in)	I holes	J holes	K mm (in)	L mm (in)	M mm (in)	N mm (in)	Weight kg (lb)	Main conn.	Drain conn.
44 -series	770 (30,31)	700 (27,56)	360 (14,17)	438 (17,24)	51 (2,00)	257 (10,12)	260 (10,24)	149 (5,87)	24x M16/ UNC 5/8"	24x M20/ UNC 3/4"	676 (26,61)	320 (12,59)	-	100 (3,93)	520 (1150)	BSP	BSP
64 -series	858 (33,78)	790 (31,10)	430 (16,93)	450 (17,72)	56 (2,19)	264 (10,39)					766 (30,16)	390 (15,35)			750 (1653)		
84 -series	1100 (43,31)	1020 (40,16)	530 (20,87)		66,5 (2,61)	346,5 (13,64)	560 (22,05)	198,5 (7,81)	24x M20	24x M24	955 (37,59)	440 (17,32)	620 (24,41)	-	1550 (3417)	BSP 2"	BSP 1"

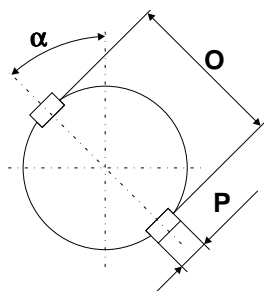
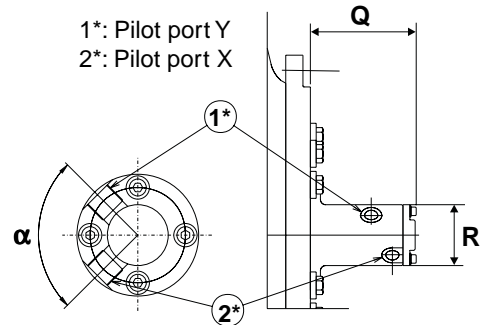


Table 1a Key & 2-speed adapter dimensions

Motor	O mm (in)	P mm (in)	Q mm (in)	R mm (in)	α
44/64 -series	274 (10,78)	50 (1,96)	-	-	45°
84 -series	-	-	200 (7,87)	115 (4,52)	90°



# Dimensions

## Torque arm

Fig. 10 Torque arm TAC-1000-K

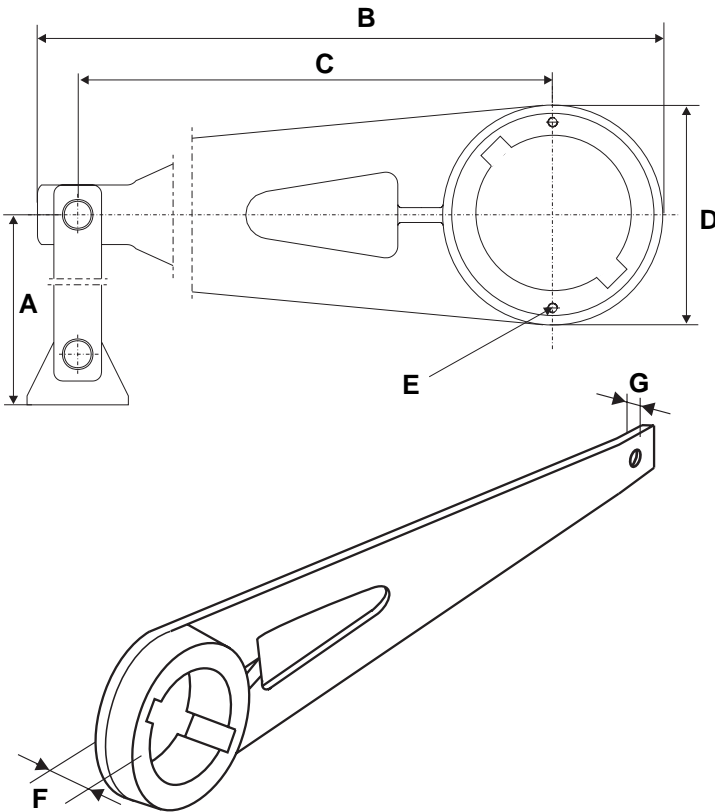
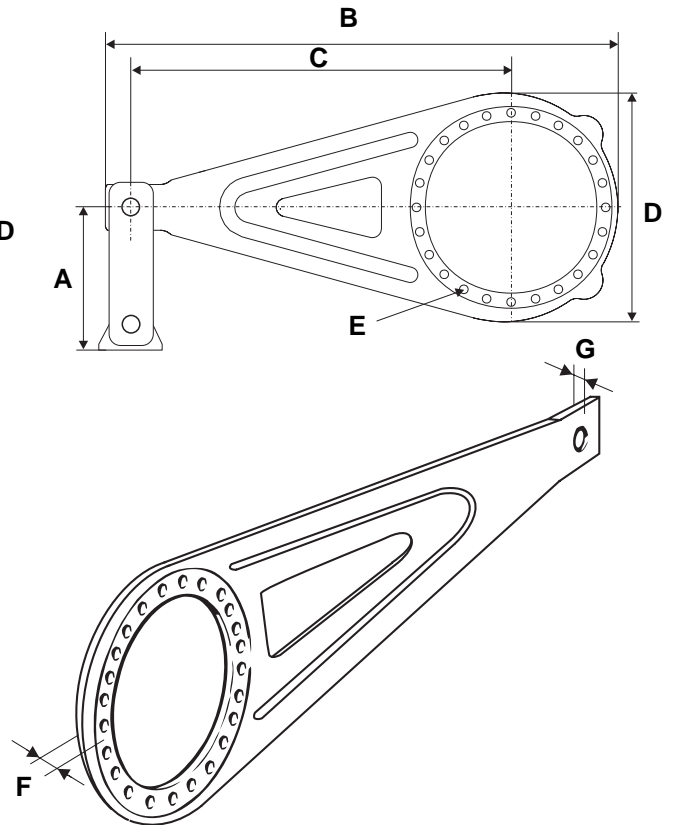


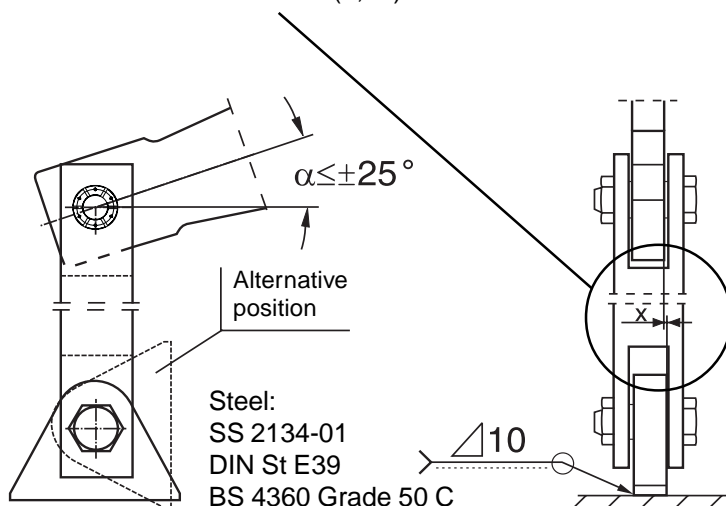
Fig. 9 Torque arm TAC-1250-B



Torque arm	A mm (in)	B mm (in)	C mm (in)	D mm (in)	E holes	F mm (in)	G mm (in)	Weight kg (lb)
TAC-1000-K	435 (17,12)	1235 (48,62)	1000 (39,37)	370 (14,57)	2xM16	99 (3,90)	35 (1,38)	85 (187)
TAC-1250-B	545 (21,46)	1680 (66,14)	1250 (49,21)	750 (29,52)	24xM24	37 (1,45)	40 (1,57)	155 (342)

Fig. 11 Mounting of pivoted attachment

$x = \pm 2 \text{ mm (0,079)}$  misalignment in installation.  
 $x \leq \pm 15 \text{ mm (0,59)}$  movement when in use.



Note: Ideal angle  $\alpha = 0^\circ$

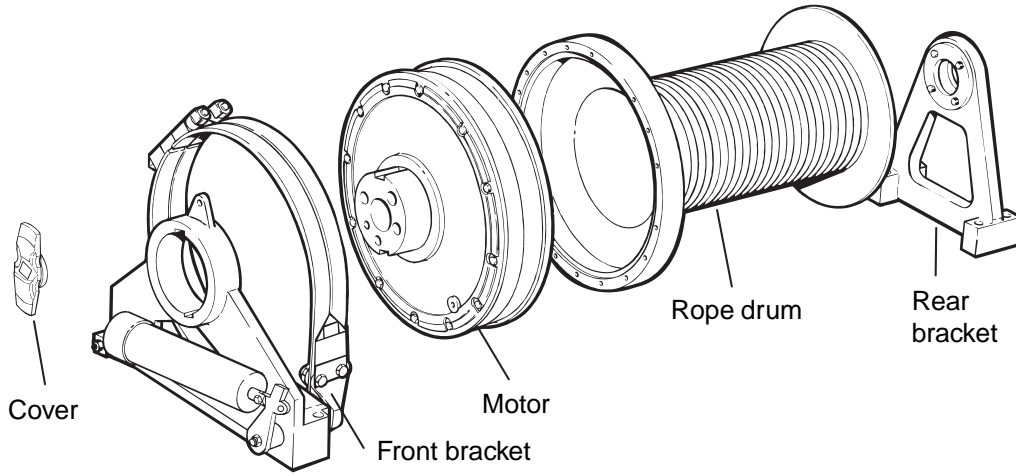
Torque arm	Max. torque (Nm) For alternating direction of torque	Max. torque (Nm) For pulsating torque	Max. torque (Nm) At static torque
TAC-1000-K For 44-series	34000*	65000**	65000
TAC-1000-K For 64-series	34000*	65000**	65000
TAC-1250-B For 84-series	152000	152000	182000
Torque arm	Max. torque (lbf-ft) For alternating direction of torque	Max. torque (lbf-ft) For pulsating torque	Max. torque (lbf-ft) At static torque
TAC-1000-K For 44-series	25000*	48000**	48000
TAC-1000-K For 64-series	25000*	48000**	48000
TAC-1250-B For 84-series	112000	112000	134000

\*Exceeding this value result in greater wear on keys and keyways.

\*\* Do not exceed  $M_b$  for motor cover, see page 21.

# Dimensions

## Brackets



Bracket	For motor	A mm (in)	B mm (in)	C mm (in)	D mm (in)	E mm (in)	F mm (in)	G mm (in)	Attachment mm (in)	Weight kg (lbs)
<b>BA-43</b> single acting	44-series	871 (34,29)	480 (18,90)	208 (8,19)	323 (12,72)	906 (35,67)	900 (35,43)	583 (22,95)	ø28 (1,102) 4 holes	220 (485)
<b>BA-43</b> double acting	44-series			224 (8,82)				-		
<b>BA-63</b> single acting	64-series	208 (8,19)		583 (22,95)						
<b>BA-63</b> double acting	64-series	224 (8,82)		-						
<b>BA-85</b> single and double acting	84-series	-	630 (24,80)	-	550 (21,65)	1188 (46,77)	1160 (45,67)	-	ø28 (1,102) 11 holes	670 (1480)
<b>RBC-46</b> rear bracket	44/64-series	590 (23,23)	480 (18,89)	40 (1,57)	190 (7,48)	80 (3,15)	540 (21,26)	-	ø28 (1,102) 4 holes	60 (132)
<b>RBC-84</b> rear bracket	84-series	750 (29,53)	630 (24,80)	50 (1,96)	230 (9,05)	100 (3,94)	710 (27,95)	-	ø35 (1,38) 4 holes	107 (236)

Fig. 12 BA-43 and BA-63, single acting

Fig. 13 BA-43 and BA-63, double acting

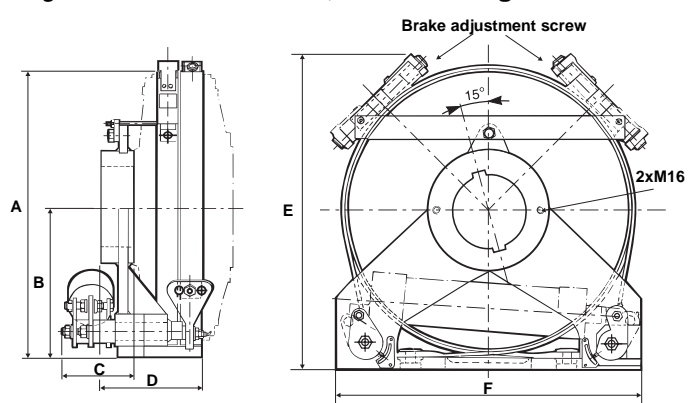
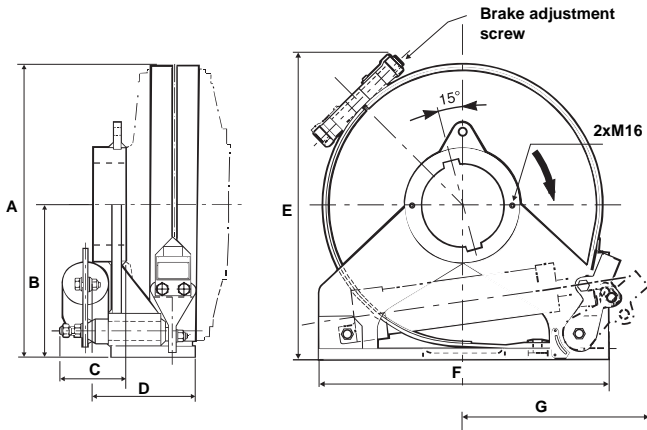
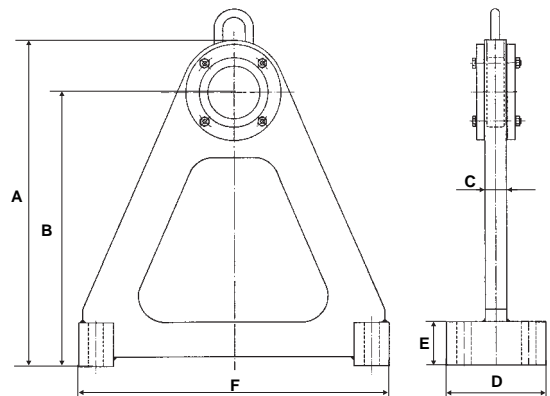
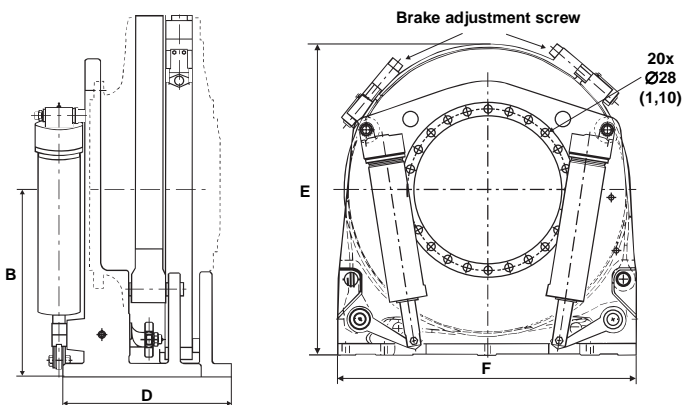


Fig. 14 BA-85, single and double acting

Fig. 15 RBC-46/84 rear bracket



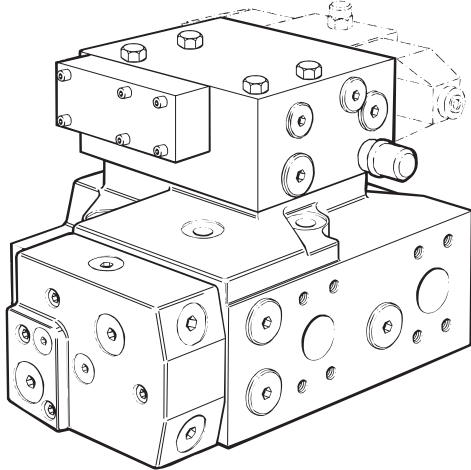
# Accessories

## Winch valve for open systems, type V46-O

Winch valve V46-O is designed for open systems together with motors of series 44 and 64, and particularly for suspended load applications. It is a counter balance valve, controlled from the low pressure side, combined with a displacement shifting function. It also includes crossover relief valves and a special valve for brake operation. The valve is mounted directly on the motor.

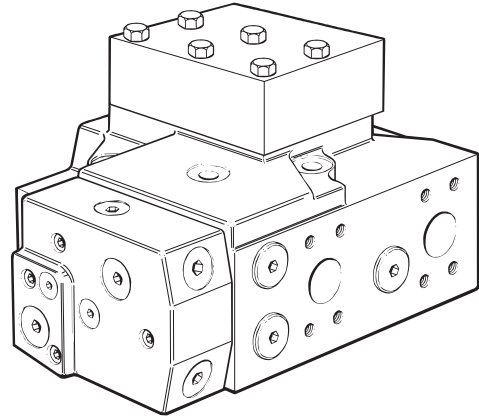
Working pressure: 210-350 bar (3000-5000 psi)      Capacity: 800 l/min (211 US. gal/min)  
Weight: V46-O-1, 110 kg (242 lb) and V46-O-2, 100 kg (220 lb)

Fig. 16 Valve V46-O-1, with control block



**V46-O-1:** The valve is delivered with a control block, affording advanced safety and control function for displacement shifting.

Fig. 17 Valve V46-O-2, without control block



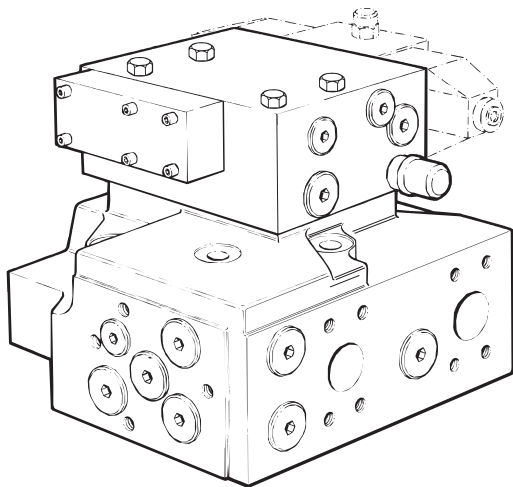
**V46-O-2:** The valve is delivered without a control block and must be supplemented with control function.

## Winch valve for closed systems, type V46-C

Winch valve V46-C is designed for closed systems together with motors of series 44 and 64, and particularly for suspended load applications. It is a combined unloading and displacement shifting valve with built-in functions for pressure limitation and oil exchange, thus eliminating the need for a transmission valve. The valve is mounted directly on the motor.

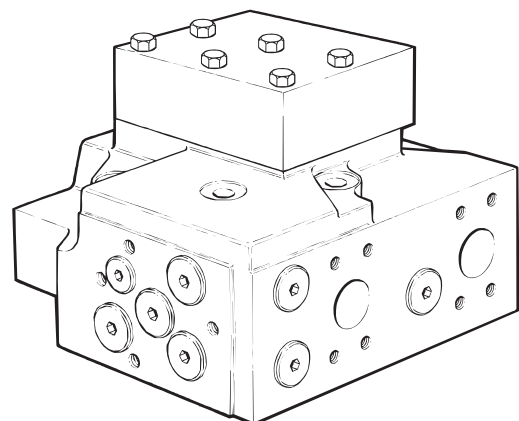
Working pressure: 210-350 bar (3000-5000 psi)      Capacity: 800 l/min (211 US. gal/min)  
Weight: V46-C-1, 90 kg (190 lb) and V46-C-2, 80 kg (175 lb)

Fig. 18 Valve V46-C-1, with control block



**V46-C-1:** The valve is delivered with a control block, affording advanced safety and control functions. Functions needing to be actuated are start, stop and selection of motor displacement. This is accomplished by a solenoid valve (must be ordered separately), which is mounted directly on the control block.

Fig. 19 Valve V46-C-2, without control block



**V46-C-2:** The valve is delivered without a control block and must be supplemented with all directional control and control functions.

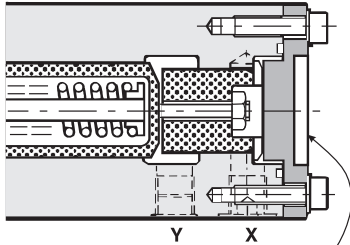
# Accessories

## 2-speed valve for 84-series

The 84-series motor it is possible, if a two speed valve is selected to set displacement ratios 1:2 and 1:3. The differences between a two-position and three-position valve are only the position of the end cover and that the "X-port" is plugged.

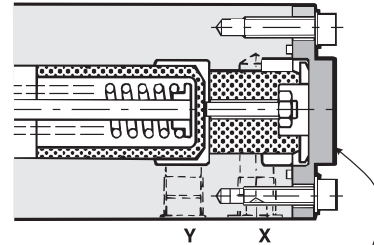
**Note:** Displacement shifting is not allowed when the motor is running.

Fig. 20 Two-position valve



The end cover in this position, and pilot-port "X" plugged gives a two-position valve.

Fig. 21 Three-position valve



The end cover in this position, and pilot-port "X" plugged gives a three-position valve.

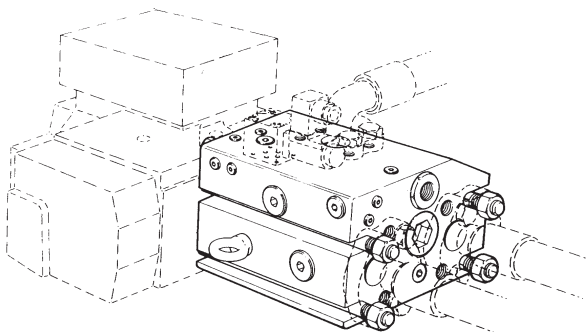
## Free wheeling valve for closed and open loop systems, type VFW

Free wheeling valve VFW is designed for both closed and open hydraulic systems together with motors of series 44, 64 and 84.

Working pressure: max 350 bar (5000 psi). Capacity: 800 l/min (211 US. gal/min)

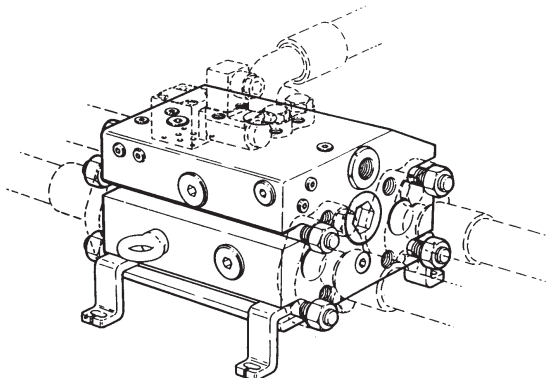
Weight: 56 kg (124 lb)

Fig. 22 Valve VFW, mounted with valve V46



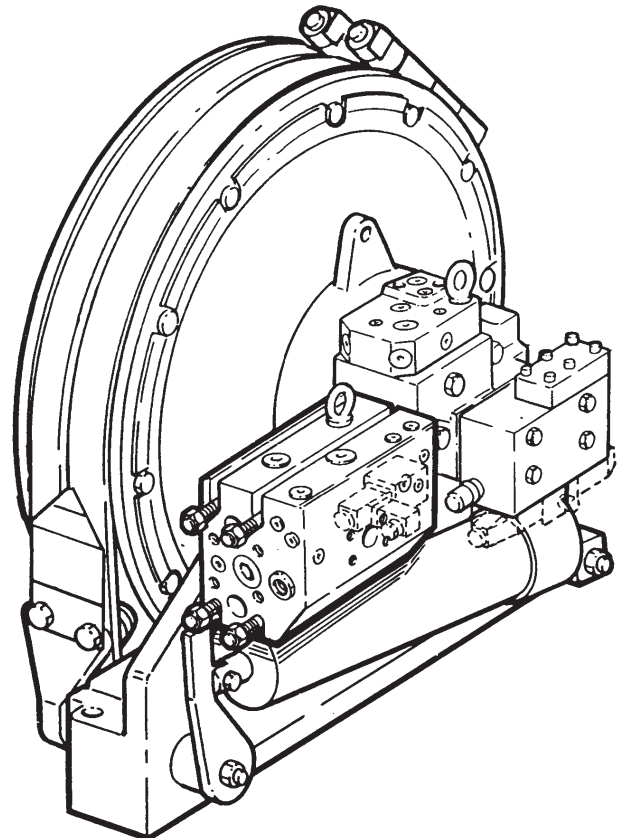
The VFW valve is mounted directly on the winch valve type V46-C or V46-O (44/64-series).

Fig. 23 Valve VFW, mounted separately



The VFW valve is mounted to the system with hoses. Directional control valve has to be added (84-series).

Fig. 24 Fitting of valve V46 and valve VFW on motor series 44/64



# Accessories

## Brake bracket, type BB-46 and BB-85

## Brake assembly, type BA-43, BA-63 and BA-85

Each brake is available in three versions depending on their brake direction, clockwise, counter clockwise and double acting. The Viking band brakes are fatigue resistant for the maximum motor torque in each motor series. The brake is intended to be used as a parking brake. For hanging loads in wet environments we recommend the use of a protective cover over the band brake. The brake linings are of non-asbestos material and have DNV type approval.

Fig. 25 Single acting double band, type BB 46 and BA 43/63

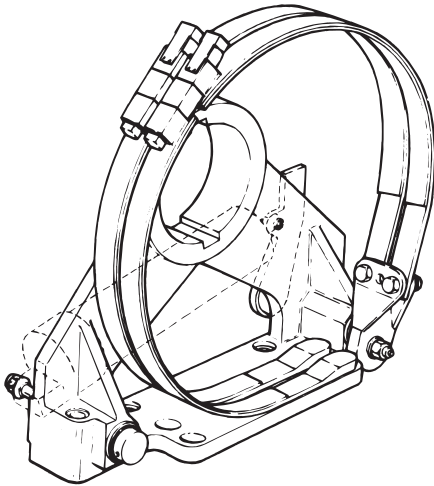


Fig. 26 Single acting double band, type BB 85 and BA 85

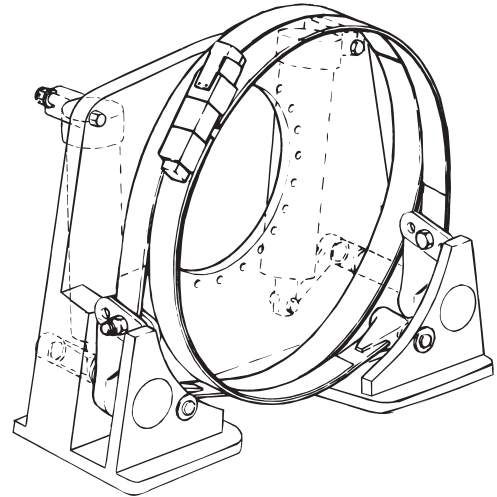


Fig. 27 Double acting, one band in either direction type BB 46 and BA 43/63

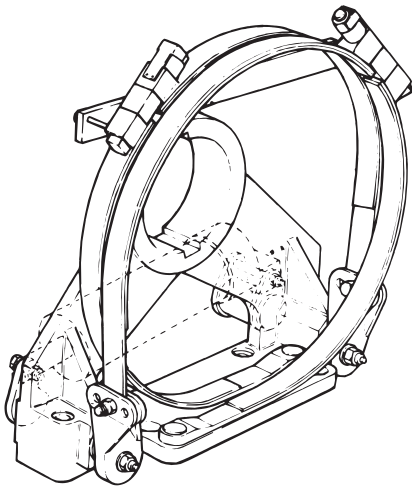
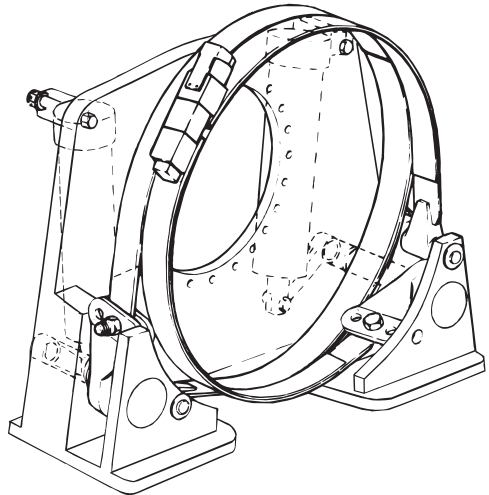
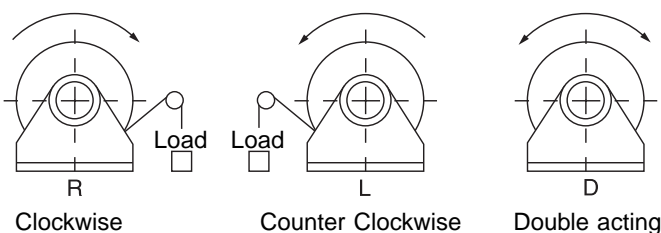


Fig. 28 Double acting, one band in either direction type BB 85 and BA 85



### Braking force direction



### Braking torque

Braking torque in braking force direction, friction factor  $\mu = 0,35$  after running-in period.

Type	Single acting - double band		Double acting	
	Nm	lbf-ft	Nm	lbf-ft
BA-43	76000	56000	55000	40500
BA-63	90000	66300	65000	47900
BA-85	195000	143800	120000	88500

# Accessories

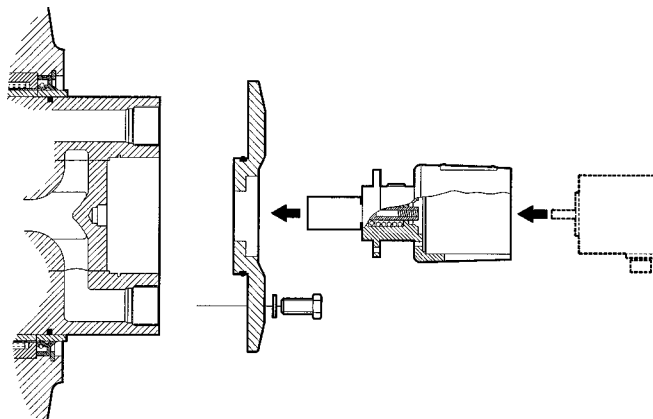
## Speed encoder with mounting set SM

Speed encoder with mounting set SM mounted on the motor (fig. 30). The Speed encoder could be ordered in 15 different models, full scale output from 2 to 300 rpm.

Fig. 29 Speed encoder



Fig. 30 Speed encoder mounted on the motor



## Parking lock unit

Parking lock unit for winch and industrial applications e.g. belt conveyor installations. The parking lock can only be used where there is no demand for dynamic braking. In addition to the locking cylinder with bracket, a ratchet-wheel (with data according to dimension drawing) must be installed on the outer mounting surface of the hydraulic motor rear cover.

Fig. 31 Industrial application

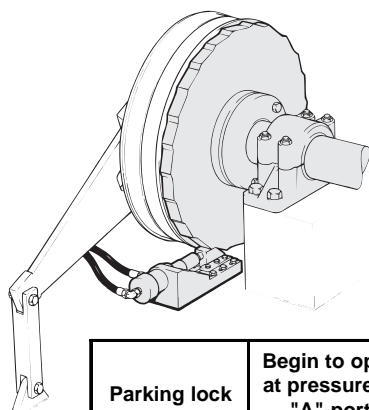
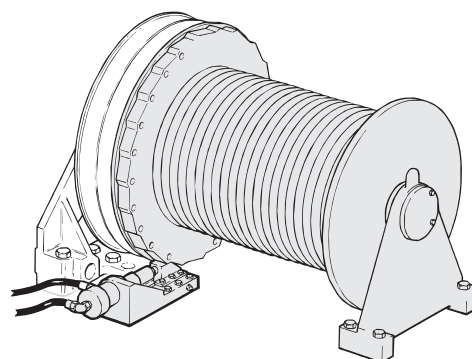


Fig. 32 Winch application



**ON** - The piston rod with its head, is pressed against the ratchet-wheel due to spring-force.

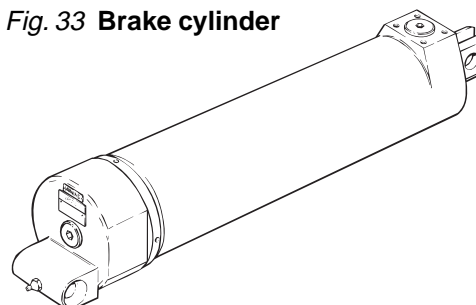
**OFF** - The piston rod is released from the ratchet-wheel by means of oil pressure.

Parking lock unit	Begin to open at pressure in "A"-port		Completely open at pressure in "A"-port		Max allowed pressure "A"-port and "D"-port		Displacement		Weight	
	bar	psi	bar	psi	bar	psi	cm <sup>3</sup>	in <sup>3</sup>	kg	lb
Cylinder	2,7	39	4,3	62	70	1000	134	8,2	23	51

## Brake cylinder, type BCI-M

For brake assembly BA-43, BA-63 and BA-85. The brake cylinder is the actuator for the Viking brakes. The bandbrake, including brake cylinder, is the fail-safe type. This means that the brake comes on due to spring force from a strong spring inside the brakecylinder, if the pressure to the cylinder is released. For good resistance to corrosion, the piston-rod is chromeplated and made of stainless steel.

Fig. 33 Brake cylinder



Brake cylinder type	Begin to open at pressure in "A"-port		Completely open at pressure in "A"-port		Max allowed pressure "A"-port and "D"-port		Displacement		Weight	
	bar	psi	bar	psi	bar	psi	cm <sup>3</sup>	in <sup>3</sup>	kg	lb
BCI-M-1X-XXX	4	58	8	115	320	4600	1300	79,3	70	154
BCI-M-30-XXX	16	230	26	380			350	21,4	70	154

# Accessories

## Protective cover, type WP-43, WP-63 and WP-85

For applications in open and wet conditions we recommend a cover to be mounted over the bandbrake. This is due to some brake efficiency losses in case of water on the lining and braking surface. The covers are made of 4 mm (0,158 in) glassfibre reinforced plastic, and are to be used with brake bracket BB-46 / BB-85.

Fig. 34 WP-43 or WP-63

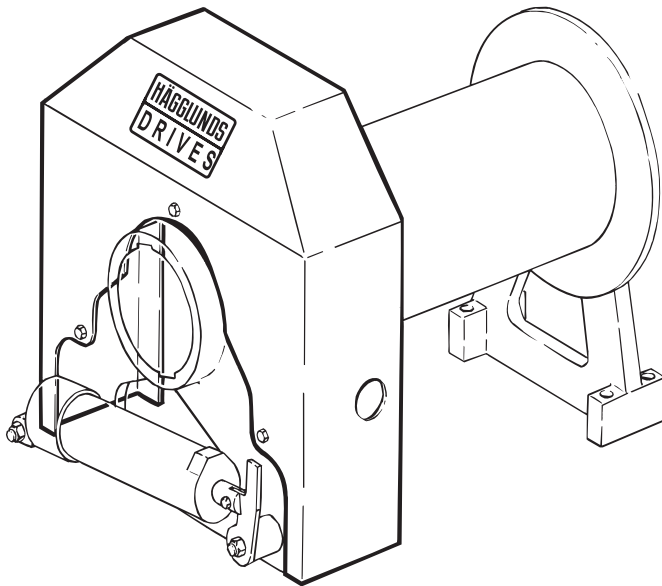
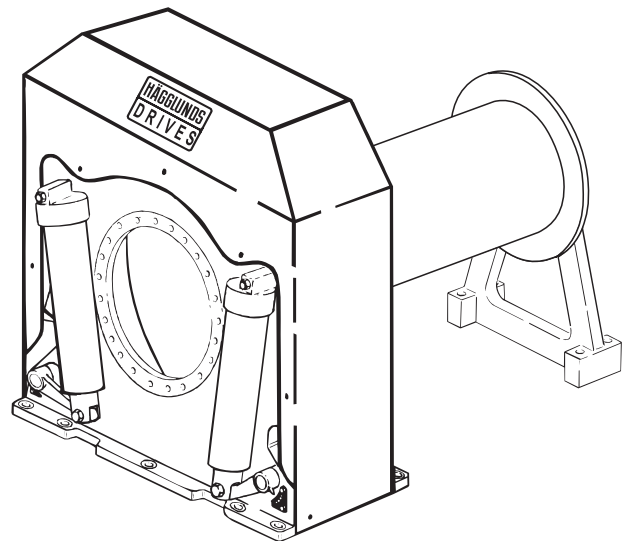


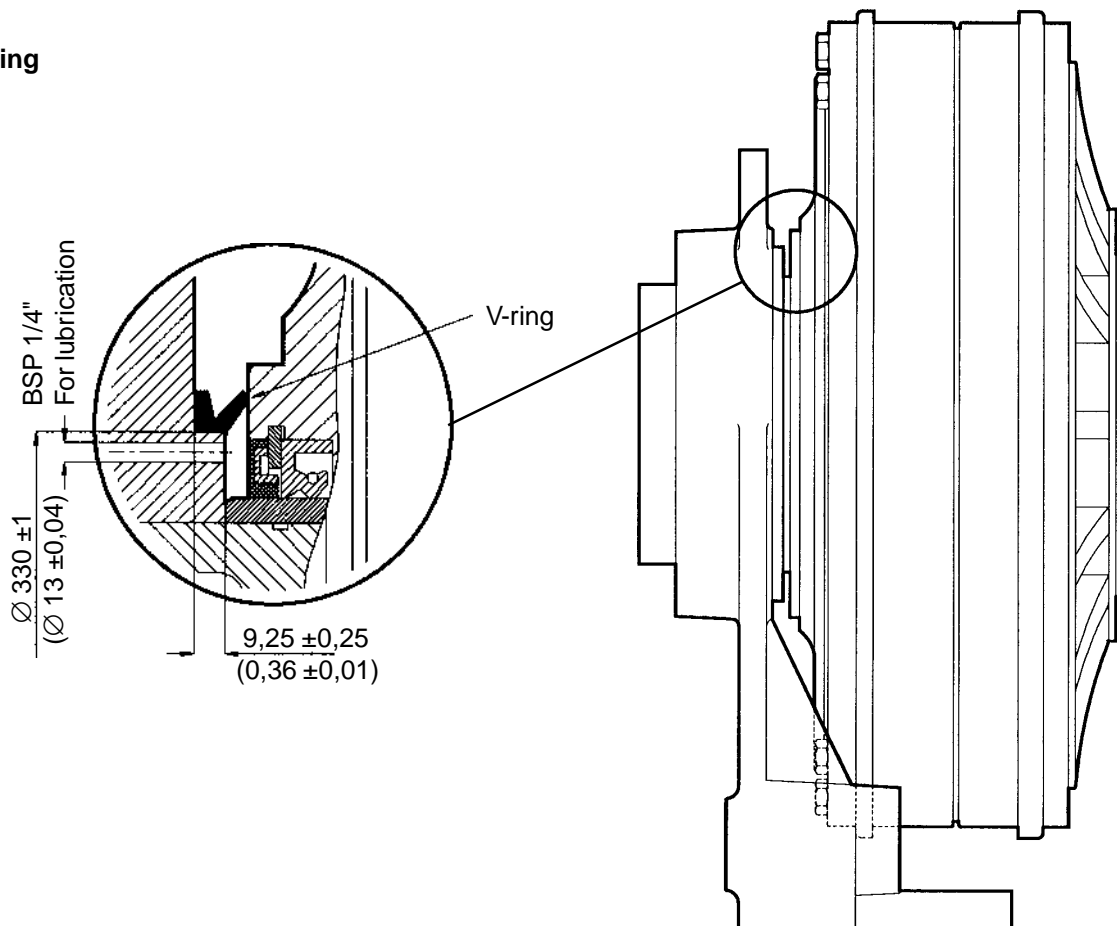
Fig. 35 WP-85



## Harsh industrial environment

To protect the main seal when the motor is used in harsh environment, an extra V-ring can be mounted on the 44- and 64-series motors. When using Häggblunds Drives bracket type BB-46, the guiding diameter is already machined.

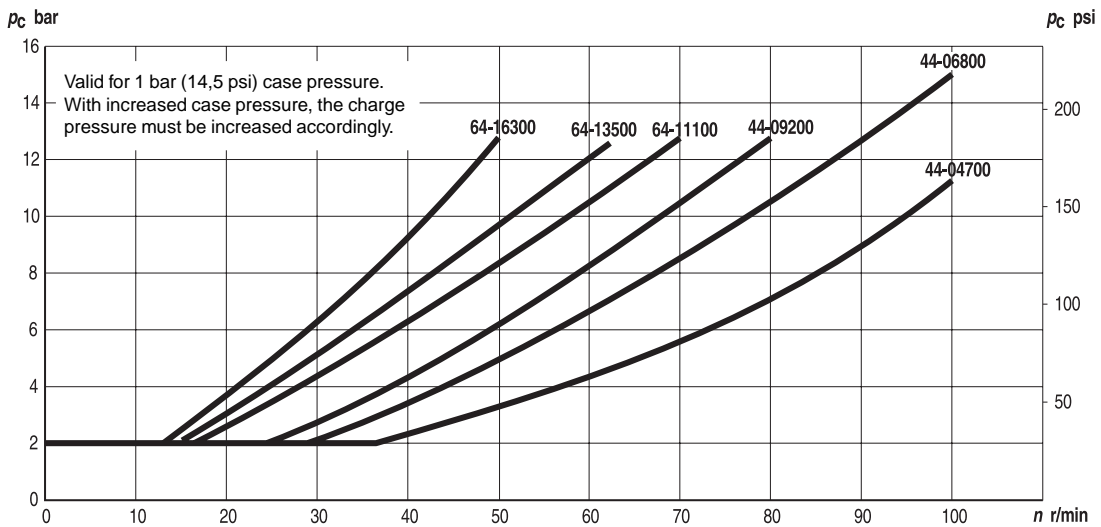
Fig. 36 V-ring



# Diagrams for Viking

## Viking motors

Diagram 1 Charge pressure - Motor series 44 & 64



**Case 1:** The motor works in braking mode. Required charge pressure at the inlet port is according to diagram above.

**Case 2:** The motor works in driving mode only. Required back pressure at the outlet port corresponds to 30% of value given in diagram above, but may not be lower than 2 bar (29 psi).

**Case 3:** The motor is used with 2-speed valve. Required charge pressure at inlet port for valve is according to diagrams.

Diagram 2 Charge pressure - Motor series 84 without 2-speed valve (A & B type)

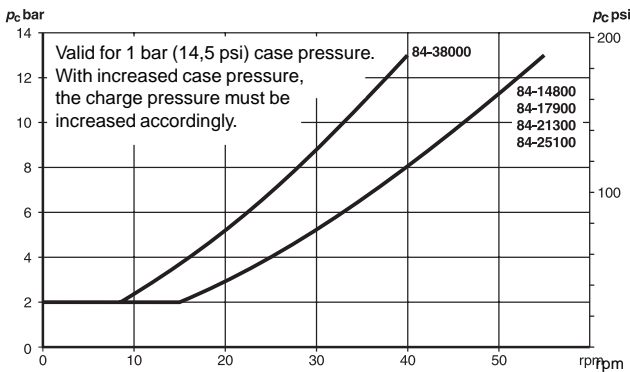
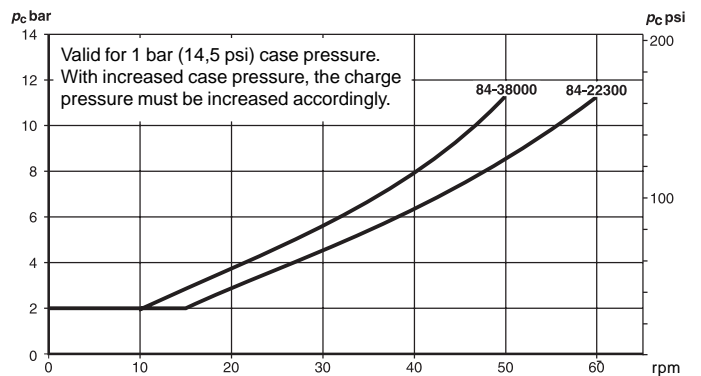


Diagram 3 Charge pressure - Motor series 84 with 2-speed valve (A & B type)



# Diagrams for Viking

## Viking motors

Diagram 4 Pressure loss through motor case

Pressure loss through motor case from  $D_1 - D_2$  (opposite flow direction gives the same pressure loss). Pressure loss represents in equal parts inlet- and outlet flow pressure loss. Viscosity 40 cSt/187 SSU.

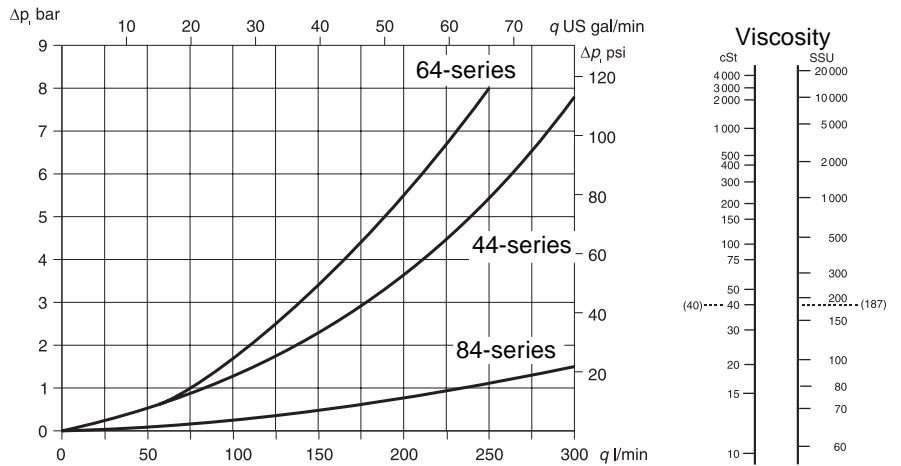


Diagram 5 Pressure loss - Motor series 44  
40 cSt/187 SSU

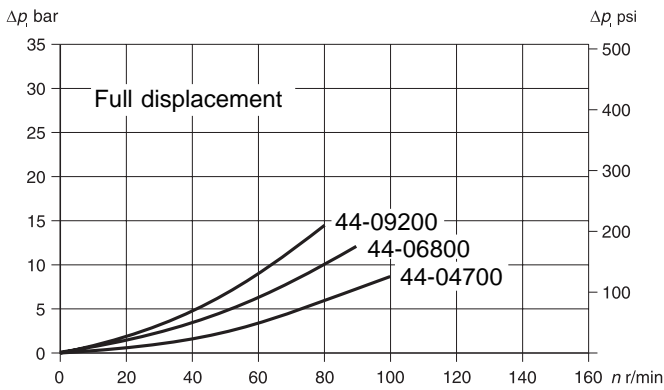


Diagram 6 Pressure loss - Motor series 64  
40 cSt/187 SSU

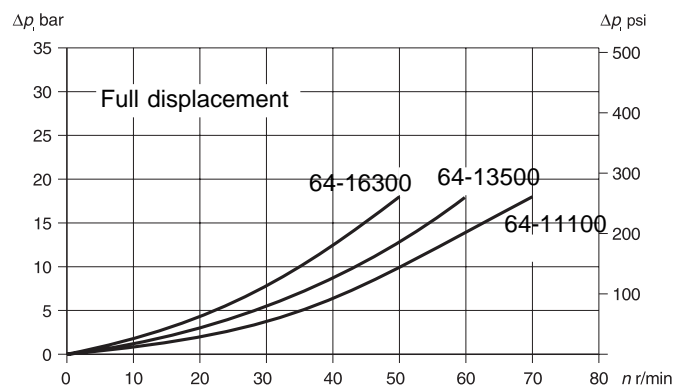
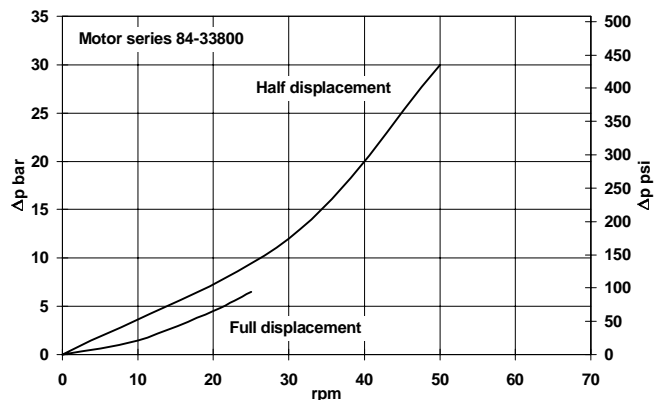
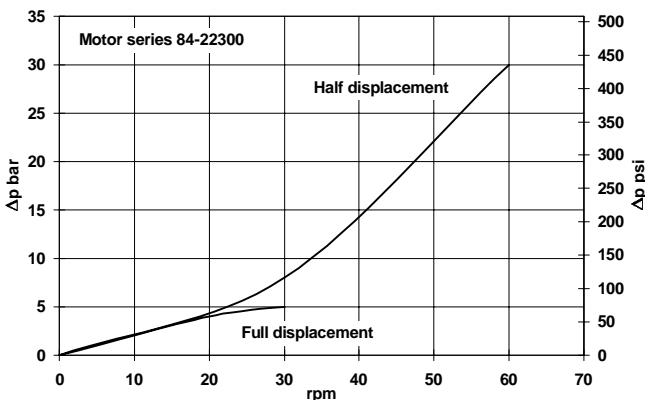
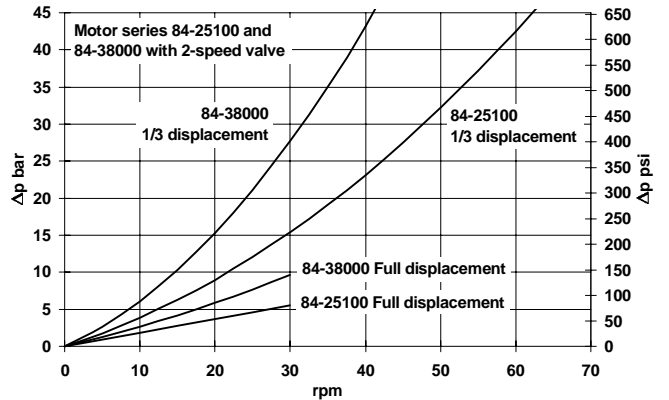
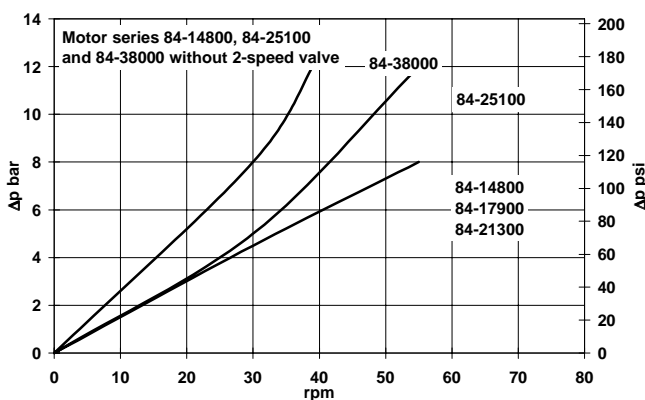


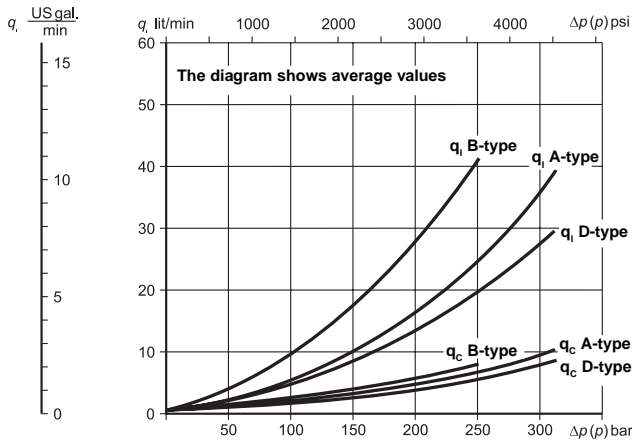
Diagram 7 Pressure loss - Motor series 84, 40 cSt/187 SSU



# Diagrams for Viking

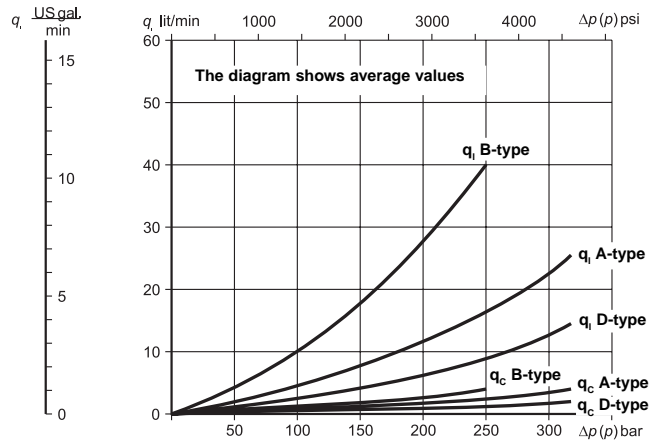
## Viking motors

**Diagram 8 Volumetric loss - Motor series 44  
40 cSt/187 SSU**



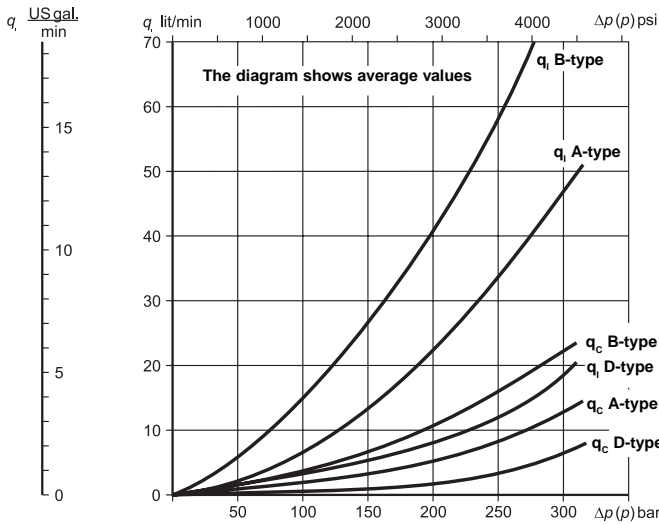
$q_i$  = Volumetric losses (incl. case drain flow).

**Diagram 9 Volumetric loss - Motor series 64  
40 cSt/187 SSU**

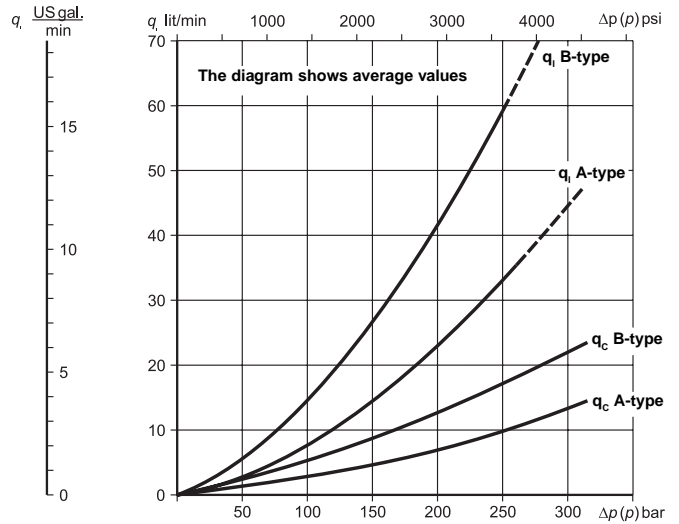


$q_c$  = Casing drain flow from D port.

**Diagram 10 Volumetric loss - Motor series 84  
without 2-speed valve, 40 cSt/187 SSU**

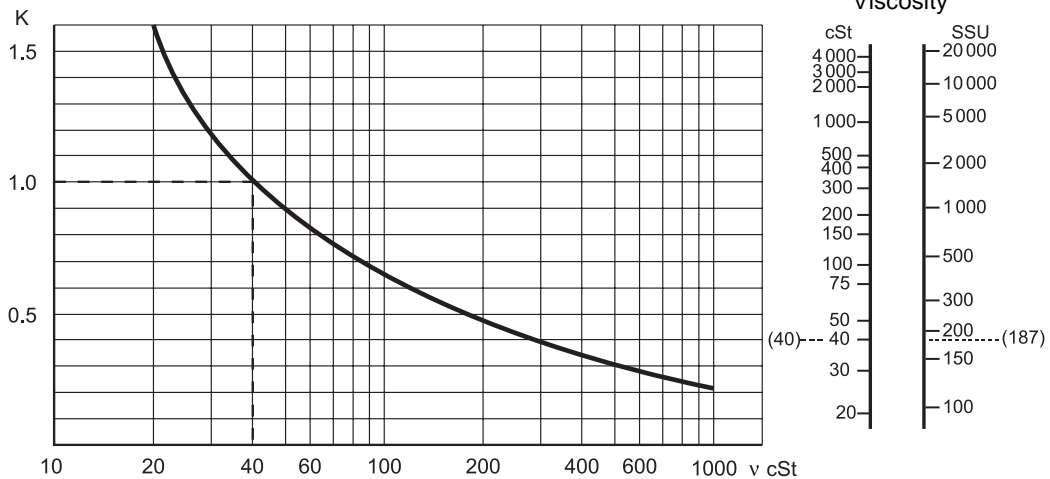


**Diagram 11 Volumetric loss - Motor series 84  
with 2-speed valve, 40 cSt/187 SSU**



The diagrams above shows the average values. When calculating volumetric losses using other viscosities, multiply the value given in the diagram by the factor K.

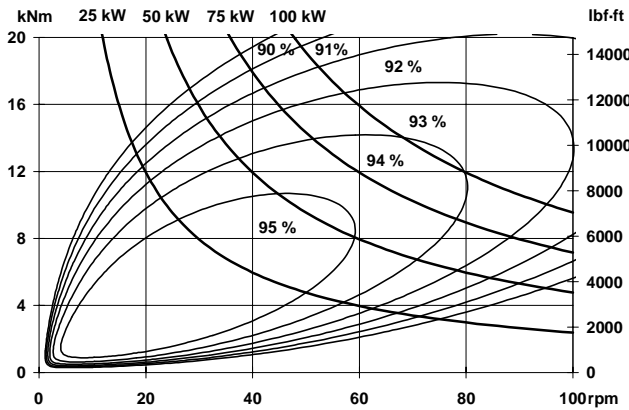
**Diagram 12 Factor K - Variation in volumetric losses**



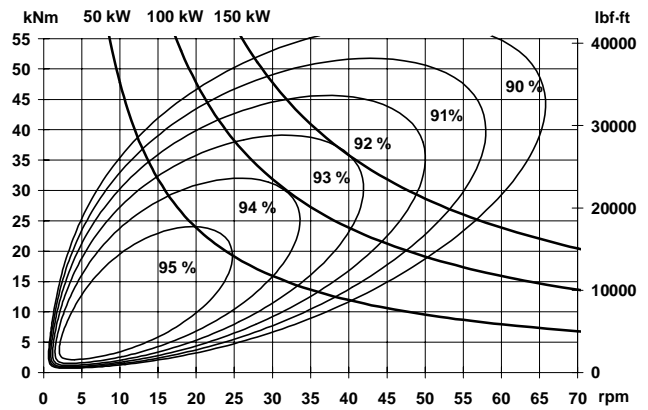
# Diagrams for Viking

## Viking motors

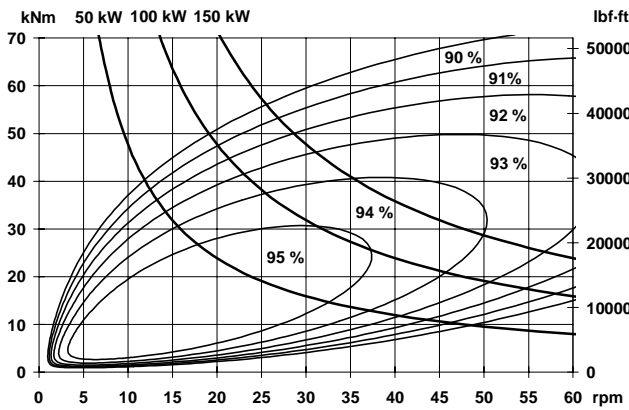
**Diagram 13 Overall efficiency - Motor type 44-04700 (A-distributor), 40 cSt/187 SSU Pc=12 bar (174 psi)**



**Diagram 14 Overall efficiency - Motor type 64-11100 (A-distributor), 40 cSt/187 SSU Pc=12 bar (174 psi)**



**Diagram 15 Overall efficiency - Motor type 84-14800 (A-distributor), 40 cSt/187 SSU Pc=12 bar (174 psi)**



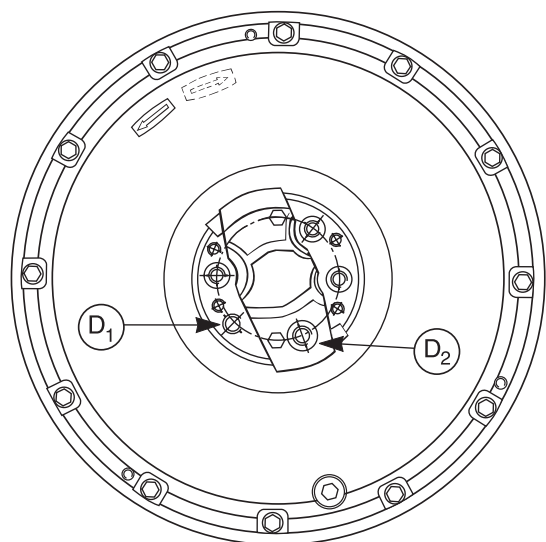
## Flushing of motor case

The Viking motors have very high total efficiency, and they are now frequently used in applications with high power. To avoid high temperature in the motor case the heat must be cooled away, because high temperature gives lower viscosity and that gives reduction in basic rating life.

- For continuous duty in applications with an ambient temperature of +20°C (68°F), the motor case must be flushed when the output power exceeds the values shown below.

Max power without flushing		
Viking 44/64	120 kW	(161 hp)
Viking 84	140 kW	(188 hp)

**Fig. 37 Flushing connection D<sub>1</sub> and D<sub>2</sub> on motor series 44 & 64**



# Examples of installations

Fig. 38 Complete Winch drive

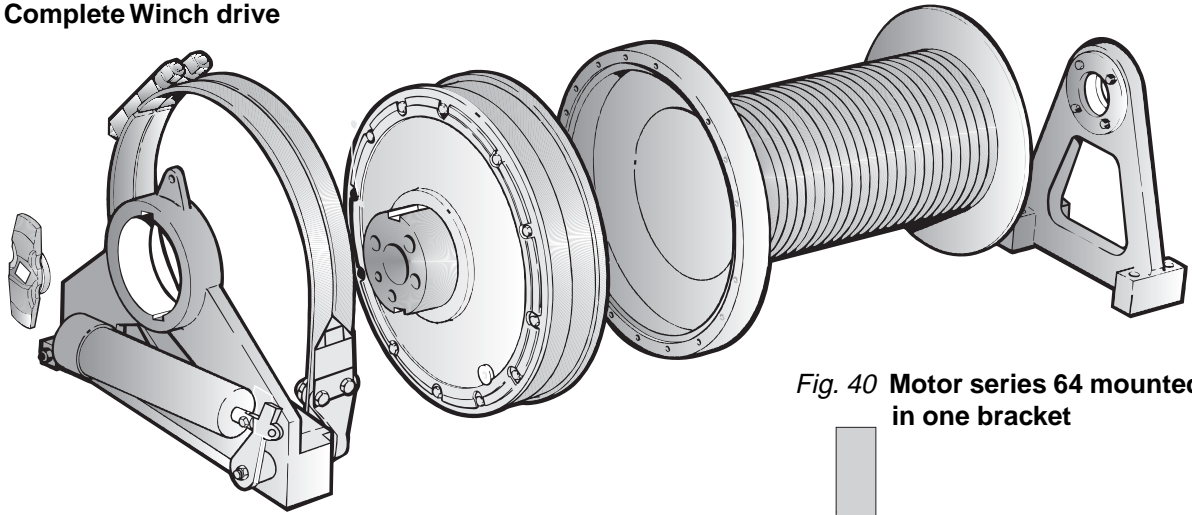


Fig. 39 Motor series 84 shaft mounted with torque arm

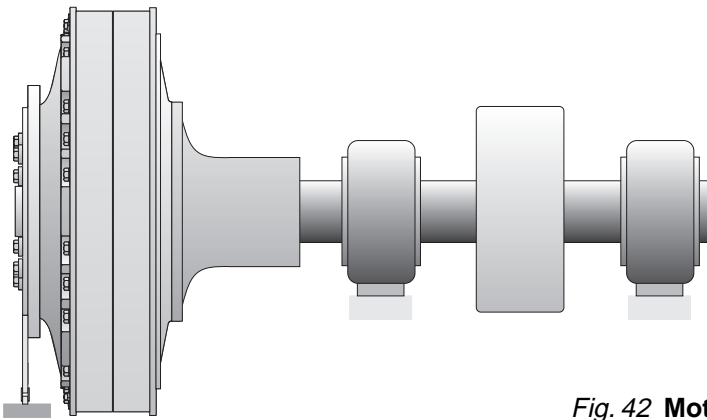


Fig. 40 Motor series 64 mounted in one bracket

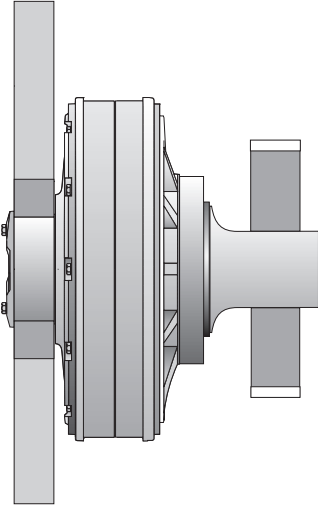


Fig. 41 Motor series 44 mounted in two brackets

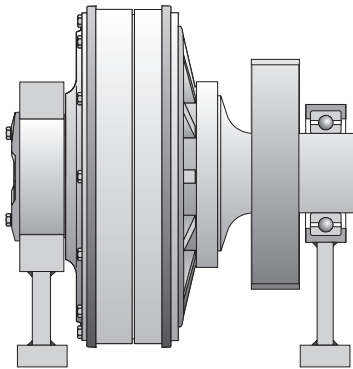


Fig. 42 Motor series 64 with V46 valve and brake bracket

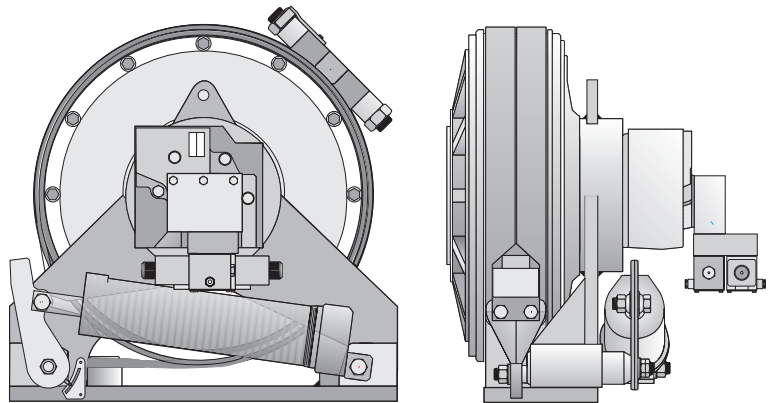


Fig. 43 Motor series 44/64 with brake bracket

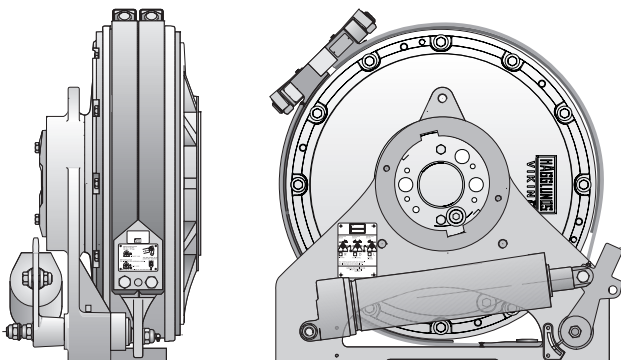
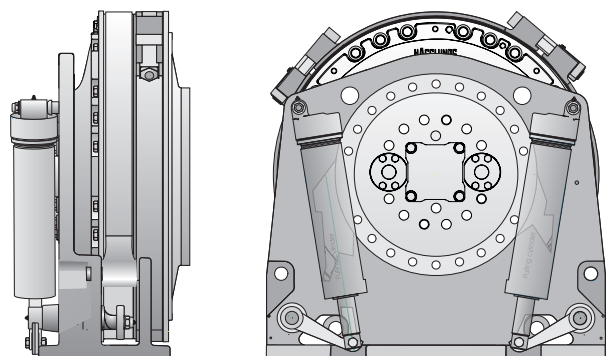


Fig. 44 Motor series 84 with brake bracket



# Calculation of external loads for Viking

Fig. 45 Motor series 44 & 64

Fig. 46 Motor series 84

Fig. 47 Shaft mounted motor with torque arm

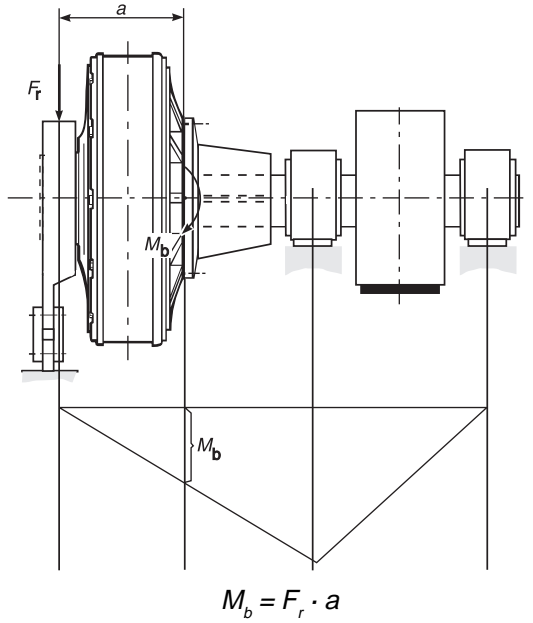
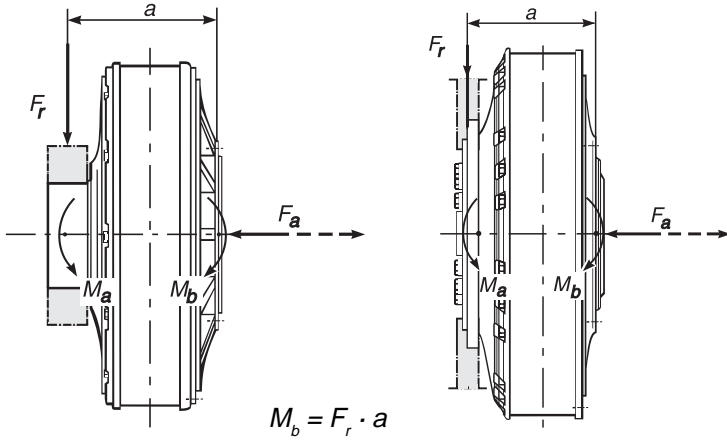
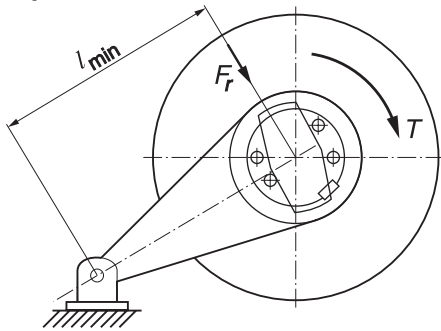


Fig. 48 Torque arm



$$T = F_r \cdot l_{min}$$

$$l_{min} = \frac{T \cdot a}{M_b}$$

$a = 350 \text{ mm (13,8 in) - 44 series}$   
 $a = 362 \text{ mm (14,3 in) - 64 series}$   
 $a = 390 \text{ mm (15,4 in) - 84 series}$

Fig. 49 Motor mounted in one bracket

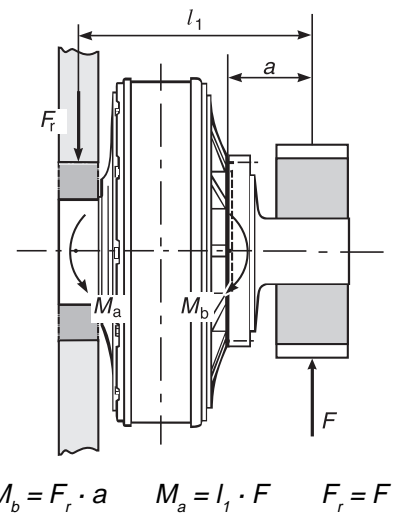


Fig. 50 Motor mounted in two brackets

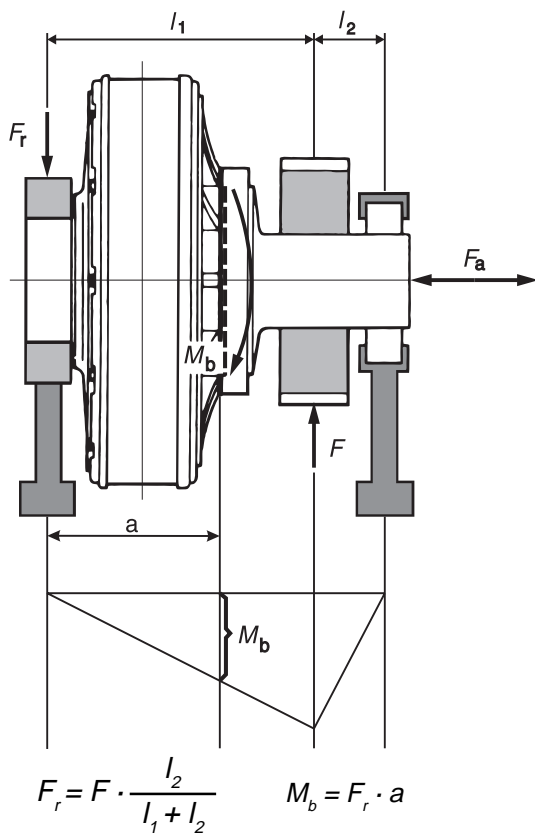
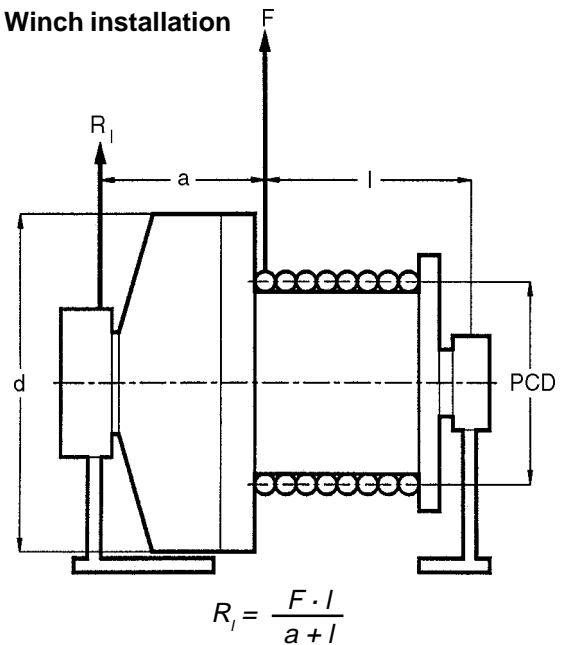


Fig. 51 Winch installation



# Max permitted external static and dynamic loads for Viking

If the torque  $M_b$  exceeds the values in the table below, static or dynamic, the outer flange must be used. In case of higher axial forces  $F_a$  than listed in the table, please contact your nearest Hägglunds Drives representative for consultation.

Motor series	Torque, $M_b$		Max. Axial force, $F_a$	
	Nm	lbf-ft	N	lbf
44	13000	9581	20000	4480
64	18000	13266	20000	4480
84	40000	29480	60000	13440

Diagram 16 Motor series 44

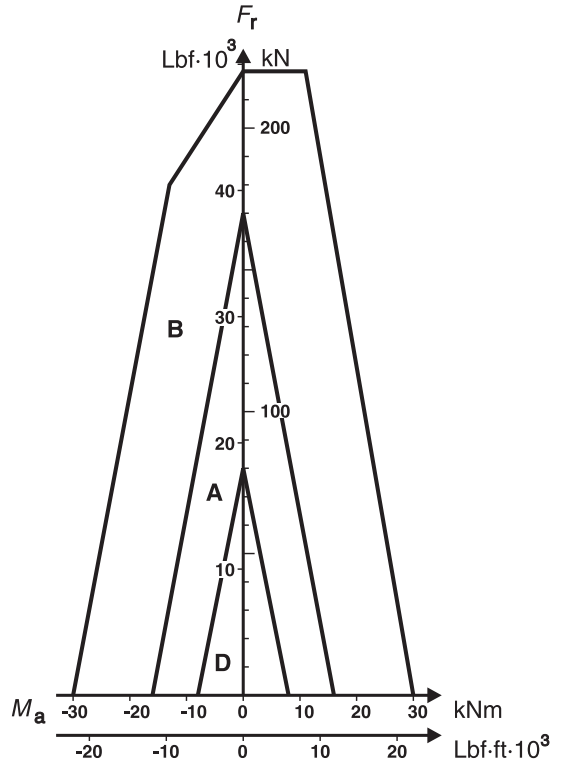


Diagram 17 Motor series 64

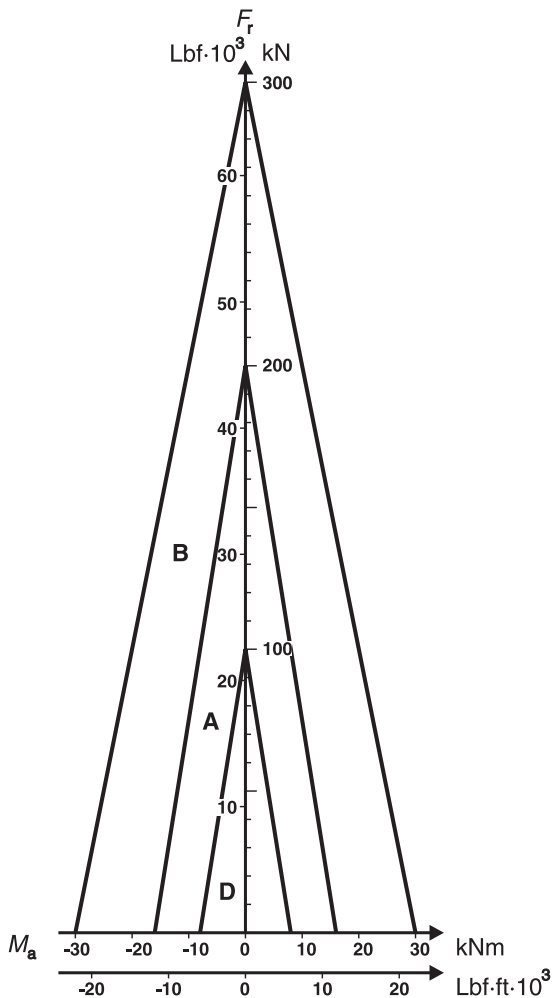
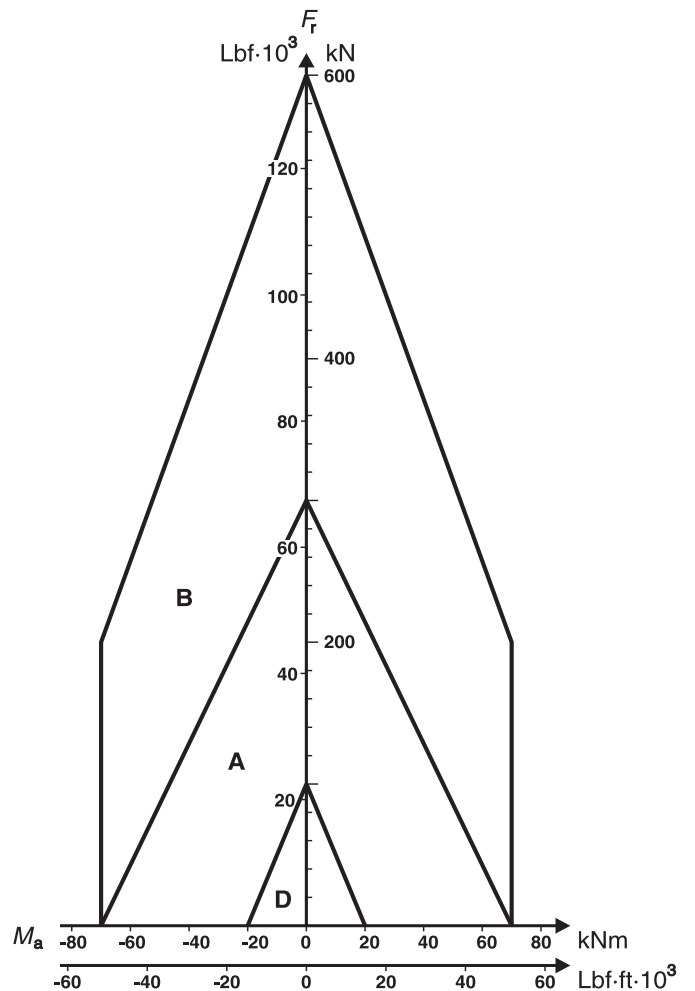


Diagram 18 Motor series 84



# Choice of hydraulic fluid

The Hägglunds Drives hydraulic motors are primarily designed to operate on conventional petroleum based hydraulic oils. The hydraulic oil can be chosen in consultation with the oil supplier or your local sales office, bearing the following requirements in mind:

## General

The oil shall have FZG (90) fail stage minimum 11 described in IP 334 (DIN 51354). The oil must also contain inhibitors to prevent oxidation, corrosion and foaming. The viscosity of mineral oil is highly dependent of the temperature. The final choice of oil must depend on the operating temperature that can be expected or that has been established in the system and not in the hydraulic tank. High temperatures in the system greatly reduce the service life of oil and rubber seals, as well as resulting in low viscosity, which in turn provides poor lubrication. Content of water shall be less than 0,1%. In Industrial applications with high demands for service life, the content of water shall be less than 0,05%.

## Recommended viscosity

At operating temperature: 40-150 cSt/187-720 SSU.

Viscosity limits	
Viscosity index	= 100 recommended = 150* for operation with large temperature difference
Min. permitted in continuous duty	40 cSt/187 SSU
Min. permitted in intermittent duty	20 cSt/98 SSU**
Max. permitted	10000 cSt/48000 SSU

\* Many hydraulic fluids with VI-improvers are subject to temporary and permanent reductions of the viscosity.

\*\* Low viscosity gives reduced basic rating life for the motors and reduction of max allowed power.

Temperature limits	
Normal operating temperature should be less than +50°C (122°F)	
Nitrile seals (std motor) Viton seals Silicone seals	-35°C to +70°C -20°C to +100°C -60°C to +70°C
Nitrile seals (std motor) Viton seals Silicone seals	-31°F to +158°F -4°F to +212°F -76°F to +158°F

## Fire resistant fluid

The following fluids are tested for Hägglunds Drives motors (ISO/DP 6071).

Fluid	Approved	Seals	Internal paint
HFA: Oil (3-5%) in water emulsion	No	-	-
HFB: Inverted emulsion 40-45% water in oil	Yes	Nitrile (std motor)	Not painted*
HFC: Water-glycol	Yes	Nitrile (std motor)	Not painted*
<b>HFD synthetic fluids</b>			
HFD:R - Phosphate esters	Yes	Viton	Not painted*
HFD:S - Chlorinated hydrocarbons	Yes	Viton	Not painted*
HFD:T - Mixture of the above	Yes	Viton	Not painted*
HFD:U - Other compositions	Yes	Viton	Not painted*

## Environmentally acceptable fluids

Fluid	Approved	Seals	Internal paint
Vegetable */** Fluid HTG	Yes	Nitrile (std motor)	-
Synthetic ** Esters HE	Yes	Nitrile (std motor)	-

\*Vegetable fluids give good lubrication and small change of viscosity with different temperature. Vegetable fluids must be controlled every 3 months and temperature shall be less than +45°C (113°F) to give good service life for the fluid.

\*\*Environmentally acceptable fluid give the same servicelife for the drives, as mineral oil.

# Choice of hydraulic fluid

## Down rating of pressure data and basic rating life

Down rating of pressure, for motors used in systems with fire resistant fluids, the maximum pressure for motor given on data sheet must be multiplied with following factors:

HFA-fluid	not fit for use
HFB-fluid	0,7 x maximum pressure for motor
HFC-fluid	0,7 x maximum pressure for motor
HFD-fluid	0,9 x maximum pressure for motor

Down rating of basic rating life, for motors used in systems with fire resistant fluids, the "expected basic rated life" must be multiplied with following factors:

HFA-fluid	not fit for use
HFB-fluid	0,26 x expected life with mineral oil
HFC-fluid	0,24 x expected life with mineral oil
HFD-fluid	0,80 x expected life with mineral oil

## Filtration

The oil in a hydraulic system must always be filtered and also new oil from your supplier has to be filtered when adding it to the system. The grade of filtration in a hydraulic system is a question of service life v.s. money spent on filtration.

In order to obtain stated service life it is important to follow our recommendations concerning contamination level.

When choosing the filter it is important to consider the amount of dirt particles that the filter can absorb and still operate satisfactory. For that reason we recommend a filter with an indicator that gives a signal when it is time to change the filter cartridge.

## Filtering recommendations

Before start-up, check that the system is thoroughly cleaned.

1. In general the contamination level in our motors should not exceed ISO 4406 19/15 (NAS 10).
2. For heavy-duty applications the contamination level should not exceed ISO 4406 16/13 (NAS 7).
3. When filling the tank and motor case, we recommend the use of a filter with the grade of filtration  **$\beta_{10}=75$** .

## Explanation of "**Grade of Filtration**"

Grade of filtration  **$\beta_{10}=75$**  indicates the following:

**$\beta_{10}$**  means the size of particle  $\geq 10\mu\text{m}$  that will be removed by filtration.

**=75** means the grade of filtration of above mentioned size of particle. The grade of filtration is defined as number of particles in the oil before filtration in relation to number of particles in the oil after filtration.

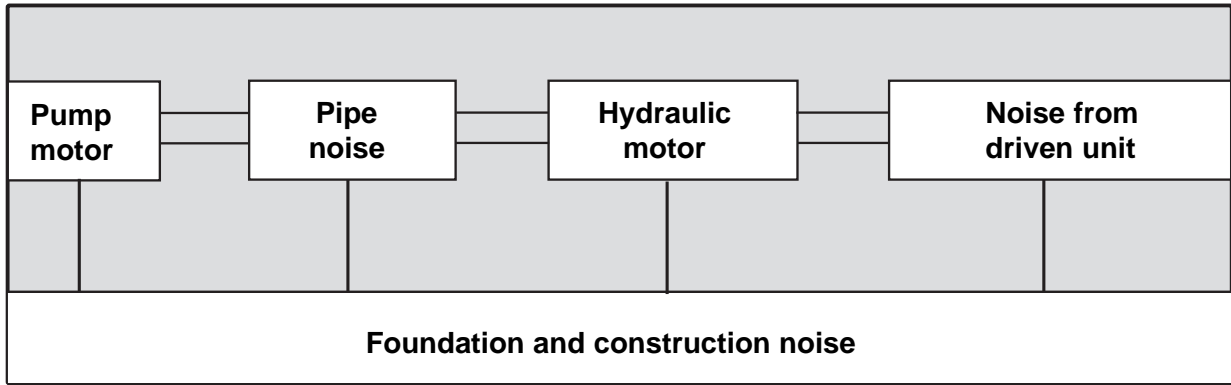
Ex. Grade of filtration is  **$\beta_{10}=75$** .

Before the filtration the oil contains  $N$  number of particles  $\geq 10\mu\text{m}$  and after passing the filter once the oil contains  $\frac{N}{75}$  number of particles  $\geq 10\mu\text{m}$ .

This means that  $N - \frac{N}{75} = \frac{74 \cdot N}{75}$  number of particles have been filtered (=98,6%).

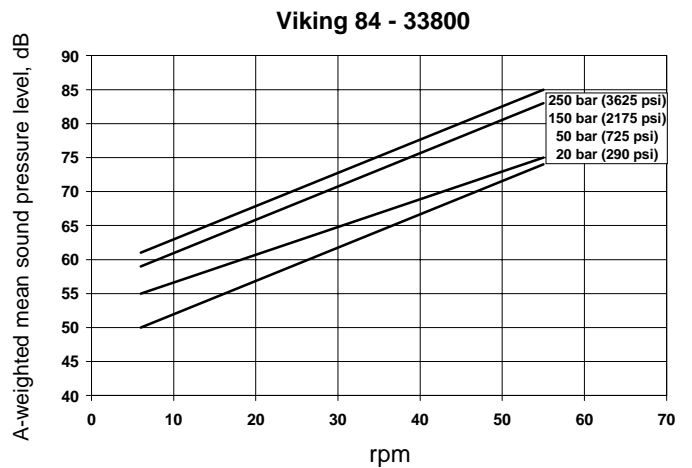
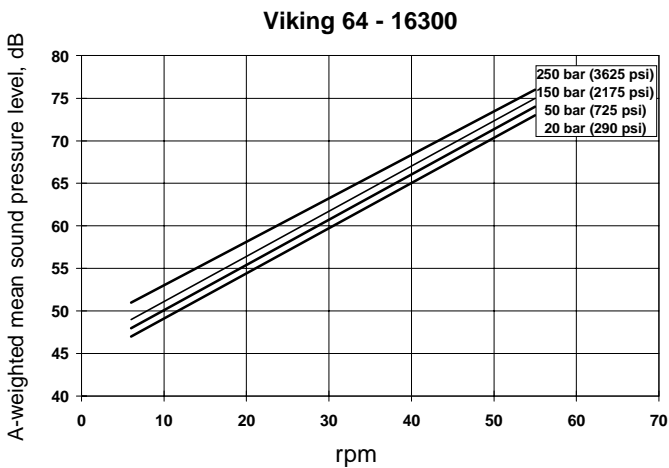
# Noise from a complete installation

## Background noise



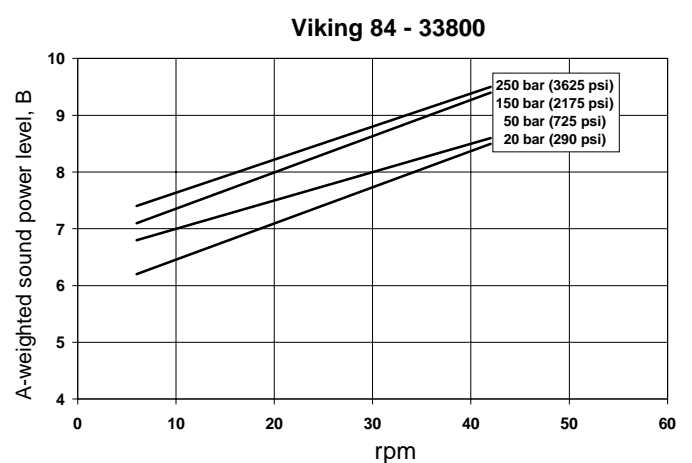
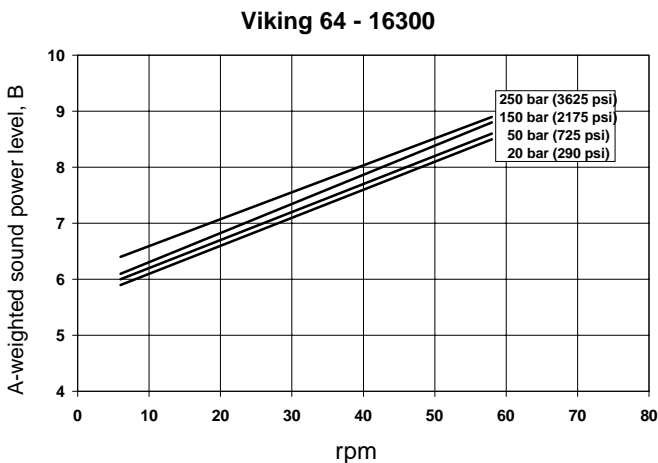
## A-weighted mean sound pressure level of Viking

The levels refer to the actual measurement room at Hägglunds Drives AB. In a measurement room with no sound reflections from walls or ceiling, the sound pressure levels are estimated to become 2-3 dB lower. All values refer to a position of the test object > 1 m. (3,28 ft).



## A-weighted sound power level of Viking


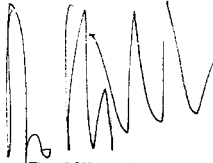
Value determined according to ISO/DIS 3747.



	Physics and Electrotechnics	TEST REPORT	Enclosure 1,2,7,8
		1985-12-17	85F30077-1,2,7,8

# Declaration of Conformity

## Example of the Declaration of Conformity given by Hägglunds Drives AB

	<b>DECLARATION OF CONFORMITY</b>
The machinery directive 89/392/EEC amended by 91/368 EEC, 93/44/EEC and 93/68/EEC and the supply of machinery (safety) regulations 1992 (SI 1992/3073).	
Manufacturer's name;	<b>Hägglunds Drives AB</b>
Manufacturer's address;	<b>S-890 42 Mellansel Sweden</b>
Contact name;	<b>Bo Hörnsten</b>
.....	
Model and/or serial numbers;	
Description of assembly;	<b>Hydraulic motor</b>
We hereby declare that the equipment detailed above has been manufactured in accordance with the above Machinery Directives, and in conformity with EN 982, EN 292-1 and EN 292-2.	
Installation, commissioning, or service of this hydraulic assembly should not be undertaken unless the recommendations in our Installation and Maintenance Manual are used in conjunction with the Machinery Directive for its incorporation within the provision of the Directive.	
Certificate of Incorporation;	
The machines above must not be put into service until the machinery into which they have been incorporated have been declared in conformity with the Machinery Directive.	
Signed;	
Name and title;	<b>Bo Hörnsten      Director Engineering</b>
Date;	<b>1995-05-31</b>

The Declaration of Conformity above, is available on request for deliveries from Hägglunds Drives AB. Translations into other languages are also available.